



TOCSIN i700

INSTALLATION AND USER INSTRUCTIONS

OLIVER IGD

OLIVER IGD Limited V10.0

4a Pepper Road
Stockport
SK7 5BW
England

Tel: +44(0)161 483 1415
Fax: +44(0)161 484 2345
Email: sales@oliver-igd.co.uk
Web Site: www.oliver-igd.co.uk



Table of Contents

Specification	3
CE Declaration	4
Overview	5
Interface Wiring	6
19" Rack Systems	16
Addressable relay Cards	17
Wiring Relay Outputs	18
Powering 3rd Party Devices	19
Operating System	20
Accepting and Resetting Alarms	21
User Menu (Password 100)	24
Zero & Calibrate Command	26
Setting Alarm Levels	27
Copy Alarms	28
Common Alarms	30
Engineering Menu (Password 50)	31
Channel Setup	34
FIND Command	36
Test Addressable Sensors	39
Testing Addressable Relays	40
Test FIRE Input Channels	41
Production Menu (Password 200)	42
Alarm Actions	43
Mimic Panels	44
Highway Splitting	45
Integrated Battery Backup	46
Battery Backup Run Time	49
Modbus	51



This product must be earthed in accordance with local safety regulations.

The Control Panel leaves the factory configured for the supply voltage stated on the customers order. Standard voltage and frequency range is:-

AC Mains Powered	230V AC (176 to 264V AC) 47 to 63 Hz
Switch Selection Option	110V AC (88 to 132V AC) 47 to 63Hz
DC Low Voltage Powered	18 to 30V DC

NOTE: Operation on an incorrectly selected supply voltage will damage the controller

Should the control panel be used in conjunction with portable generating equipment, care should be taken to ensure that the electrical supply is within the tolerance band described above. The control panel may be stored at temperatures between 0°C and 55°C. If stored at low temperatures and then brought into a warmer environment, condensation may form on some components. In such a situation, this condensation should be allowed to evaporate prior to use of the equipment. If stored at high temperature, care should be taken to ensure that humidity condensation does not enter critical electrical components, for example the power supply. The Control Panel is designed to operate within specification for ambient temperature between 0°C and 55°C, relative humidity up to 95% (non-condensing).

!Warning !

On installation alarms will need to be configured to signal when monitored gas levels have breached safe limits. The control panel will be shipped in a semi-configured state which must be checked and configured during commissioning to match the applications cause and effect requirements. Failure to do so will result in an ineffective system.

Who should read this manual.

This manual is intended for use by trained installers of gas detection systems who are technically competent and have all necessary tools to undertake installation and maintenance on this type of equipment.

Failure to install and maintain the equipment properly can render the detection system ineffective.

You should not undertake any of the procedures in this manual if you do not have access to the correct equipment, have not undertaken training on this or similar equipment or are not technically qualified to install this equipment.

Calibration gases and test equipment is available from IGD.

Power Source	88 to 132V AC (110V AC Selected) or 176 to 264V AC (230V AC Selected) 47 to 63 Hz 150 Watts DC Option Available
Display	2 x 16 backlight LCD
Operating Temperature	0°C to 55°C
Operating Humidity	Up to 95% non-condensing
Resolution	0.00% or ppm Range Dependant
Update Rate	1 Second
Size (mm)	255 (H) x 265 (W) x 100 (D)
Protection	Standard IP54
Inputs	Up to 4 or up to 8 x 4-20mA loops
Inputs	8 analogue 4-20mA loops 2 x RS485 data highways for up to 64 detectors (700+)
Outputs (Standard)	3 x configurable SPCO relays (7 Amp non conductive load) 1 x fault SPCO relays (7 Amp non conductive load) 1 x solid state audio/sounder 24VDC 1 x solid state visual/flasher 24VDC
Outputs (Optional)	Additional 8 way relay cards, I/O Nodes Gas Detectors Check ratings for maximum I/O from PSU
Optional Equipment	Battery backup 1.2Ah or 2.4Ah
CE Declaration	BS EN61000-6-4 EMC Compatibility 'Emissions' BS EN 61000-6-2:2001 EMC Compatibility 'Immunity' BS EN 61010-1: 2001 Safety requirements, electrical equipment
Weight	3.65 KG



EC Declaration of Conformity



Issuers name and address:

Oliver IGD Limited of
Triton House
Crosby St,
Stockport,
United Kingdom

Declares that the product listed as:

TOCSIN i700

Addressable & analogue Gas Detection Control Panel

Are in conformity with the provisions of the following European Directive(s) when installed, operated, serviced and maintained in accordance with the installation and operating instructions contained in the product documentation.

2004/108/EC **EMC Directive**
2006/95/EC **Low Voltage Equipment Directive** (note not applicable to 24V DC Powered Versions)

And that the standards and/or technical specifications referenced below have been applied or considered.

- EN 61779-1:2000 Electrical apparatus for the detection and measurement of flammable gases, general requirements and test methods.
- EN 50271:2001 Electrical apparatus for the detection and measurement of combustible gases, toxic gases or Oxygen: requirements and tests for apparatus using software and or digital technologies. *Excluding requirements for SIL*
- EN 61000-6-2: 2005 EMC Generic standards. Immunity for industrial environments
- EN 61000-6-4/A1: 2011 EMC Generic standards. Emission standard for industrial environments
- EN 61000-3-2: 2014 EMC Limits. Limits for harmonic current emissions (equipment input current ≤ 16 A per phase)
- EN 61000-3-3: 2013 EMC Limits. Limitation of voltage changes, voltage fluctuations and flicker in public low-voltage supply systems, for equipment with rated current ≤ 16 A per phase

Technical File Reference T700-TF9

<p>Notified Body For ATEX and/or QAN:</p> <p>Sira Test & Certification Ltd Hazardous Area Centre, Rake Lane Eccleston, Chester, CH4 9JN. United Kingdom</p>	<p>Oliver IGD Limited operate an independently assessed ISO9001:2008 Quality Assurance System and ATEX QAN.</p> <p>Quality Assurance Certificate Number</p> <p style="text-align: center;">023827</p> <p>Quality Assurance Notification Number</p> <p style="text-align: center;">SIRA 02ATEX M174</p>	<p>Testing Agency:</p> <p>TUV - SUD Octagon House Concorde Way PO 15 5RL Fareham</p>	 <p>Mehr Sicherheit. Mehr Wert.</p>
---	--	--	--

TUV Certificates and reports can be checked on-line at https://www.tuev-sued.de/industry_and_consumer_products/certificates
Select Oliver IGD when prompted on the website to view certificates

Issued by: Oliver IGD Limited, Stockport, SK2 6TS , United Kingdom

Signature:  Declaration of Conformity in accordance with EN ISO/IEC 17050-1:2004

Name Andrew J Collier M.I.O.D

Position: Managing Director Date: 1.June 2015 Declaration Ref: I700-DEC-1



Tel: +44 (0)161 483 1415
Fax: +44 (0) 161 484 2345
Email: sales@internationalgasdetectors.com
Website: www.internationalgasdetectors.com



Tocsin 700 Panel Overview

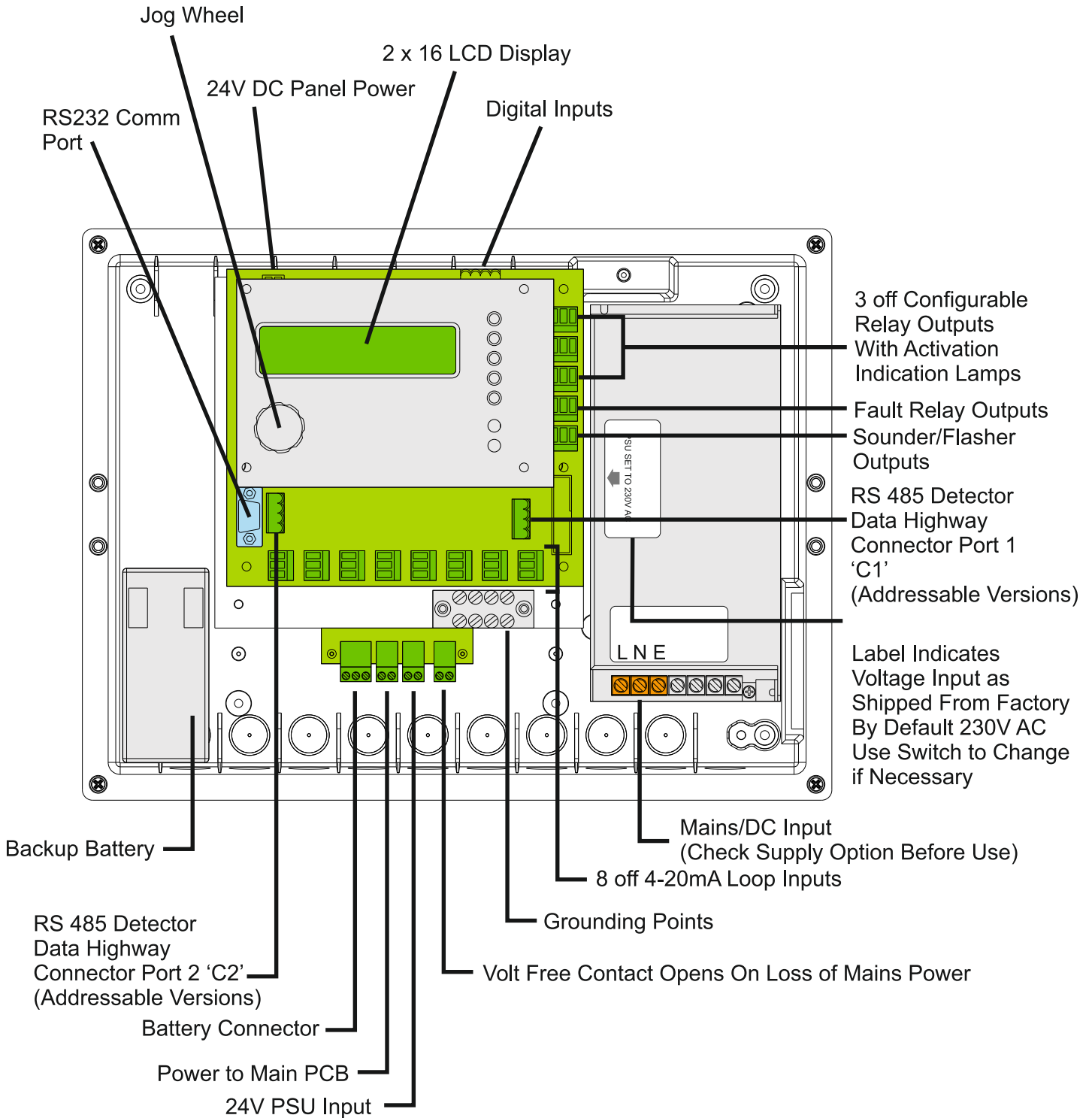

IMPORTANT

Control panels are usually shipped pre-configured with a basic alarm strategy. Before installation check the documentation provided to ensure the programmed cause and effect matches the site requirement. If it does not then the system will need to be re-programmed by the installer using the embedded panel software or PC based T700 setup software.

When first powering systems which include an IGD battery backup the batteries **MUST** be connected first for correct operation. During initial startup the panel software will check the battery condition, if mains power is applied first then the batteries cannot be functionally checked and the panel will report an error.

Tocsin 700 Interface wiring

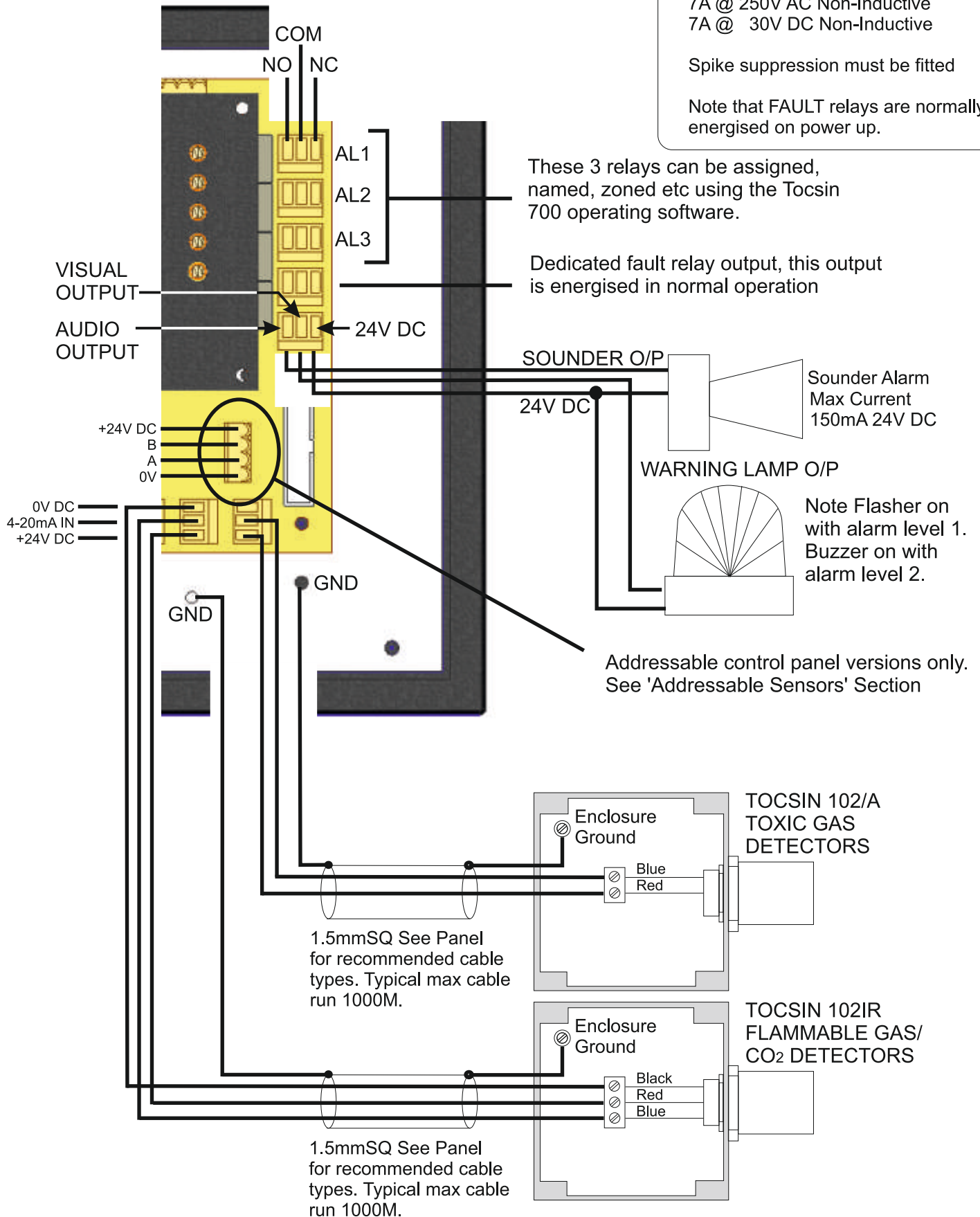

Tocsin 700 Interface wiring...continued

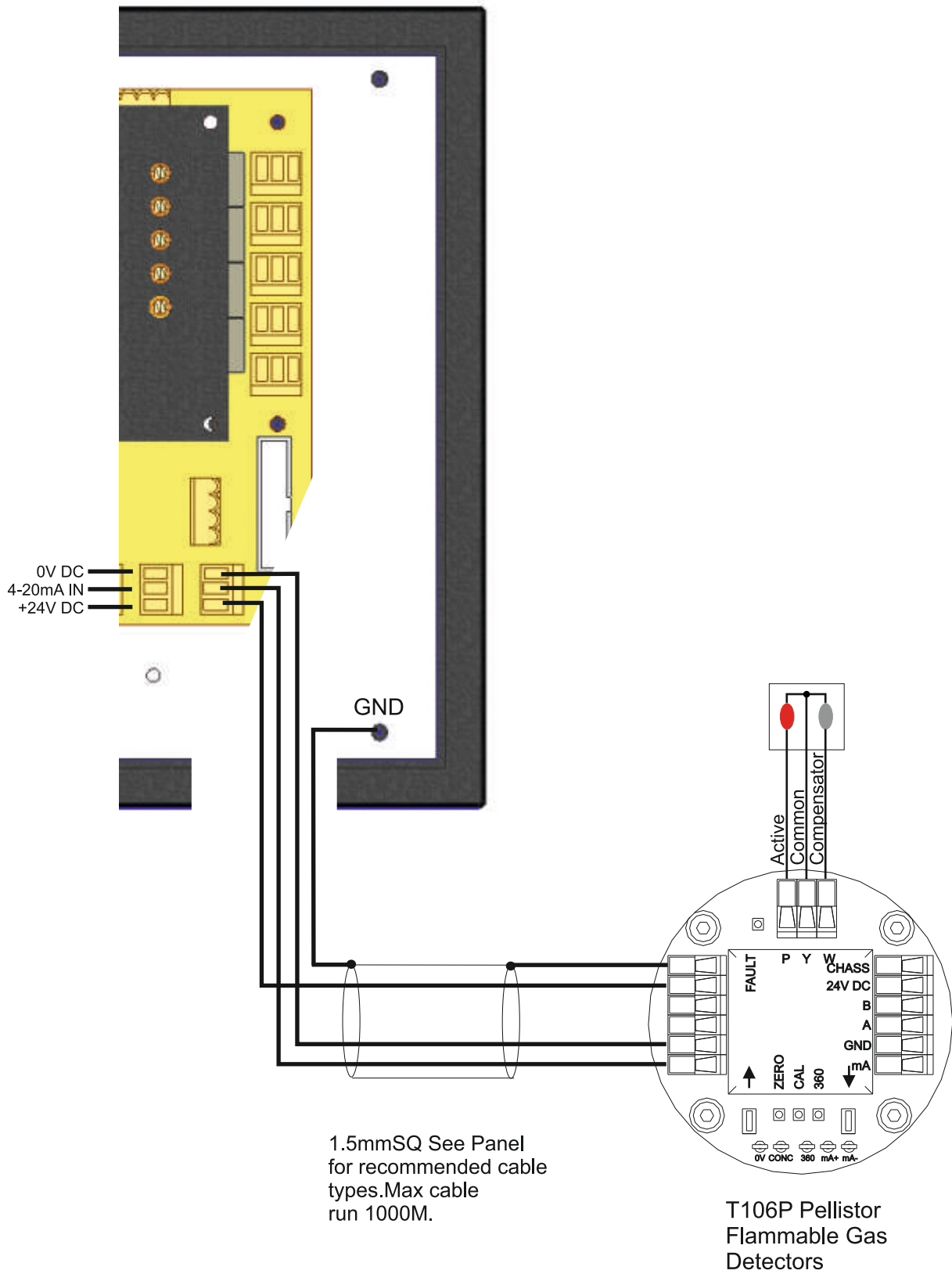

Tocsin 700 Interface wiring...Digital Port

Located at the top edge of the Tocsin 700 card is a 4 way connector used to allow digital interface to the Tocsin 700 operating system as follows:

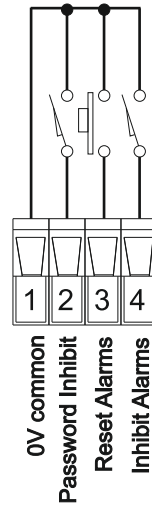
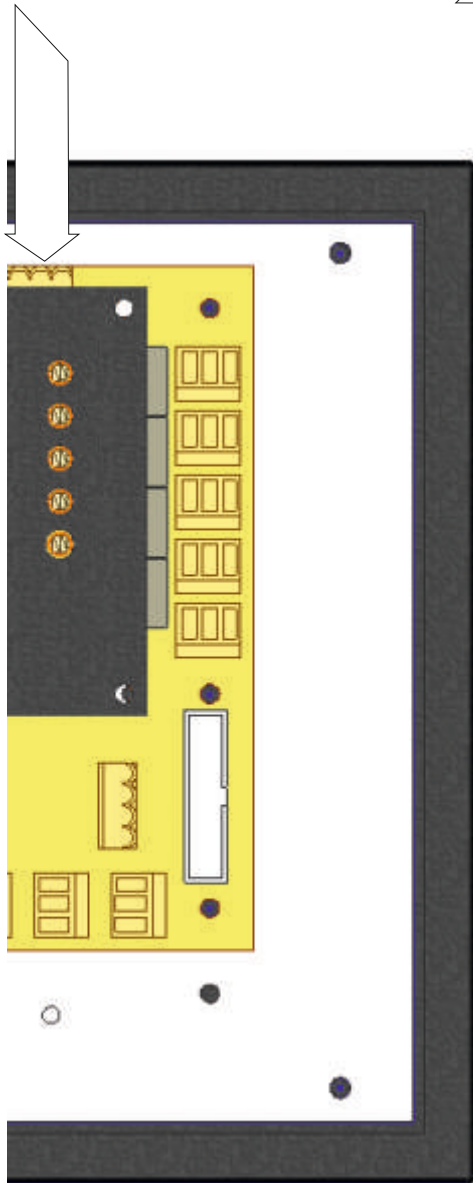

Tocsin 700 Interface wiring...continued

Tocsin 700 to Tocsin 103 2 wire Detector Series

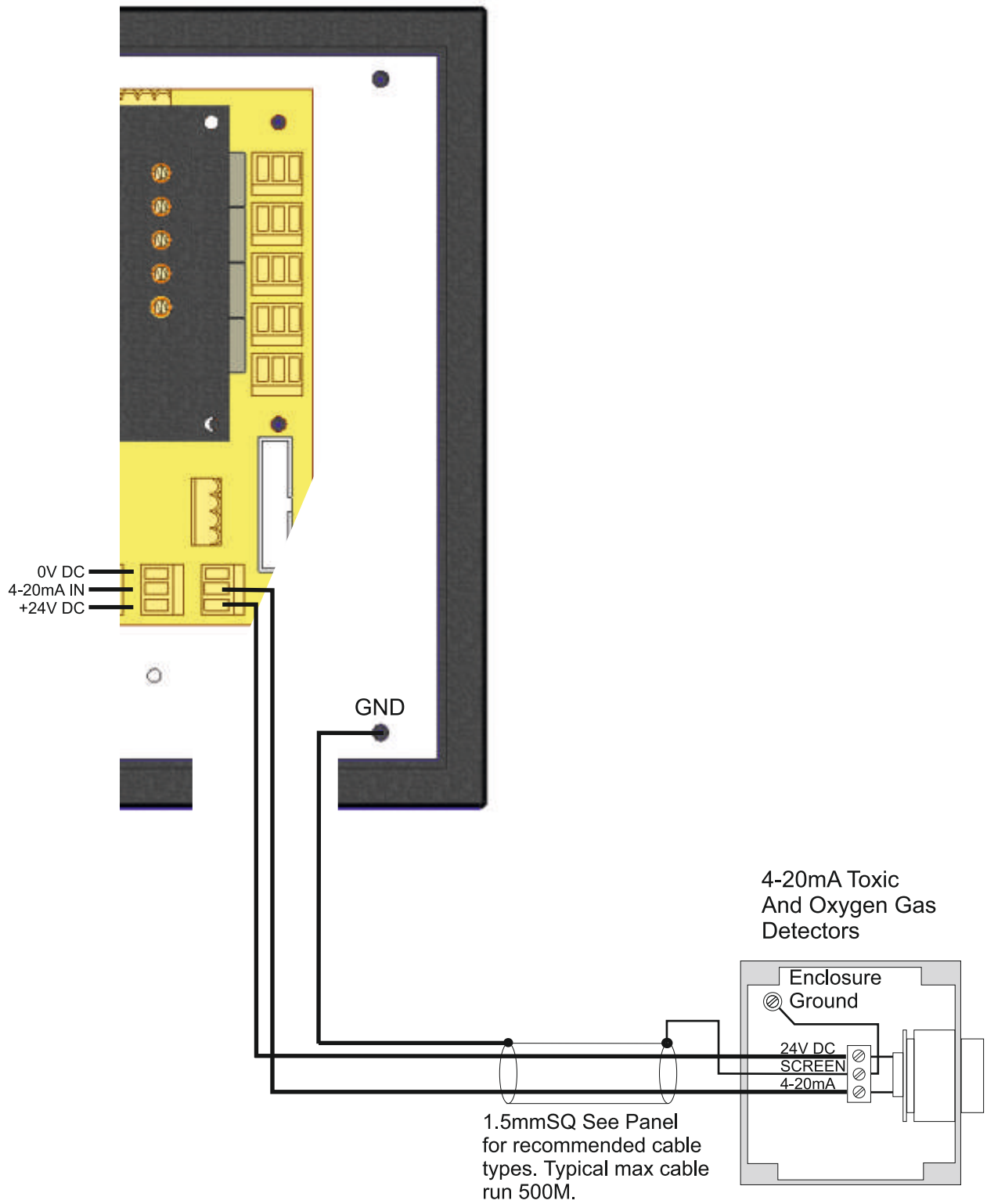

Tocsin 700 Interface wiring...continued

Tocsin 700 to Tocsin 103 3 wire Detector Series

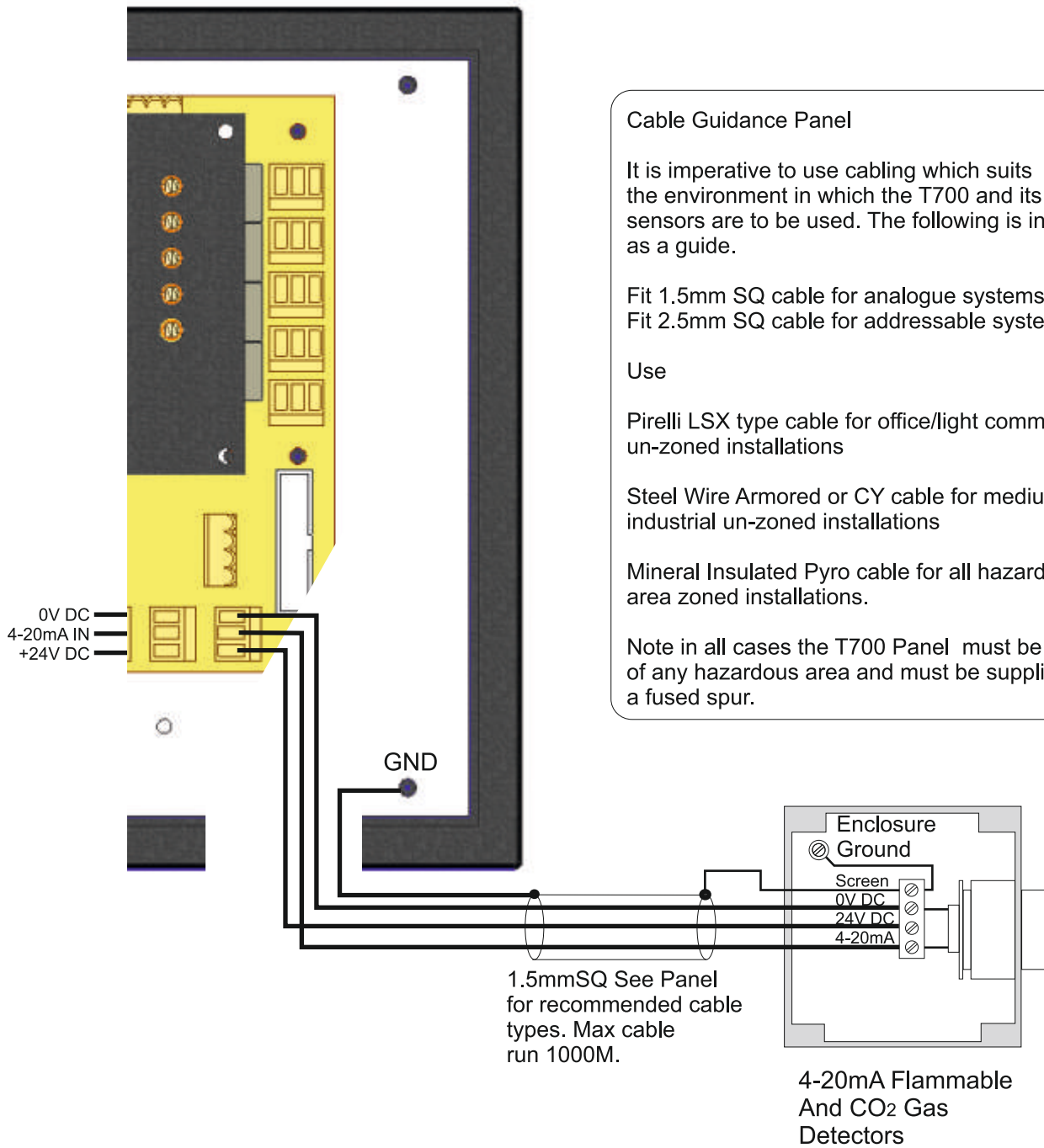

Cable Guidance Panel

It is imperative to use cabling which suits the environment in which the T700 and its sensors are to be used. The following is intended as a guide.

Fit 1.5mm SQ cable for analogue systems
Fit 2.5mm SQ cable for addressable systems

Use

Pirelli LSX type cable for office/light commercial un-zoned installations

Steel Wire Armored or CY cable for medium/heavy industrial un-zoned installations

Mineral Insulated Pyro cable for all hazardous area zoned installations.

Note in all cases the T700 Panel must be installed outside of any hazardous area and must be supplied via a fused spur.

Tocsin 700 Interface wiring...continued

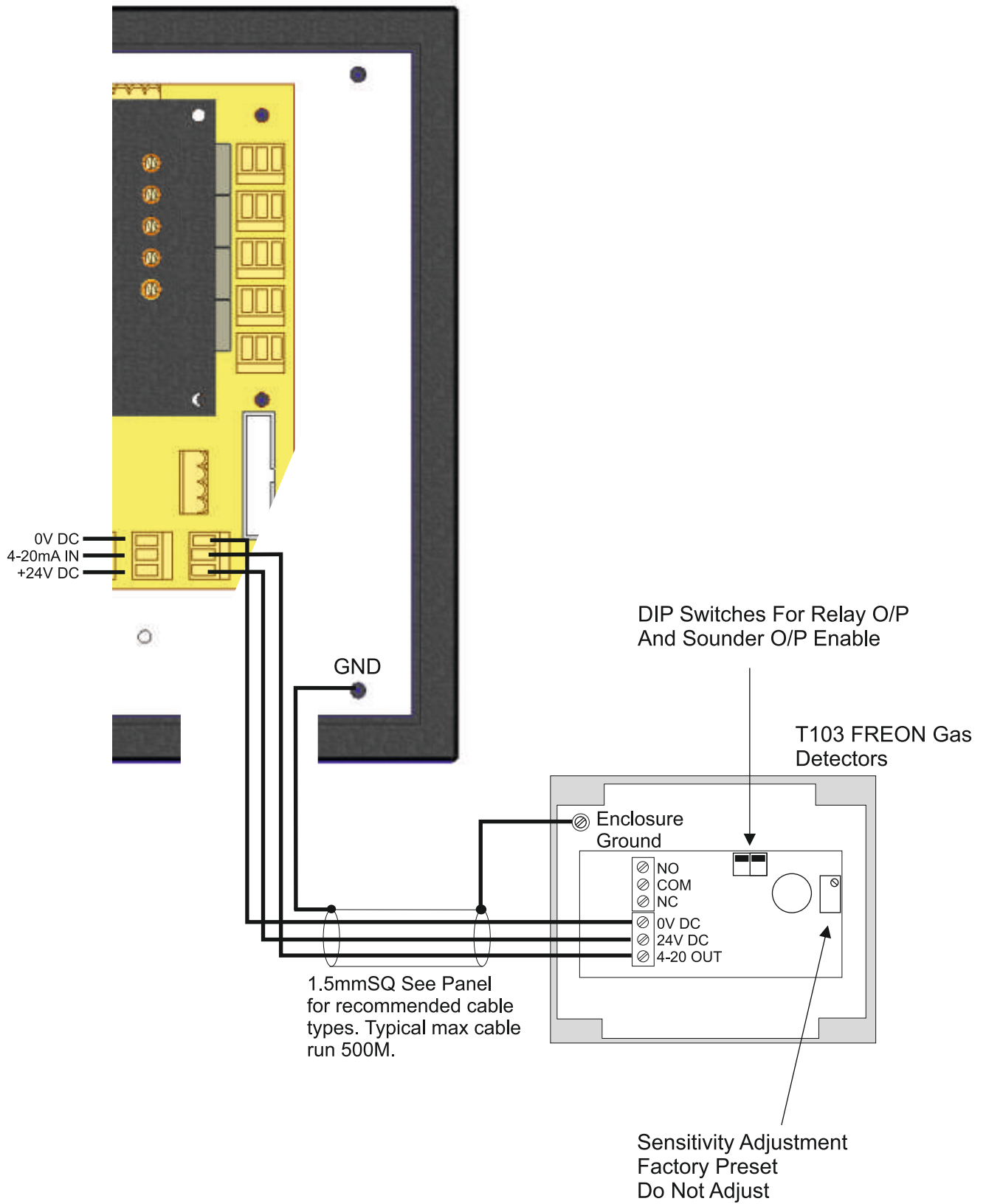

Tocsin 700 Interface wiring...continued

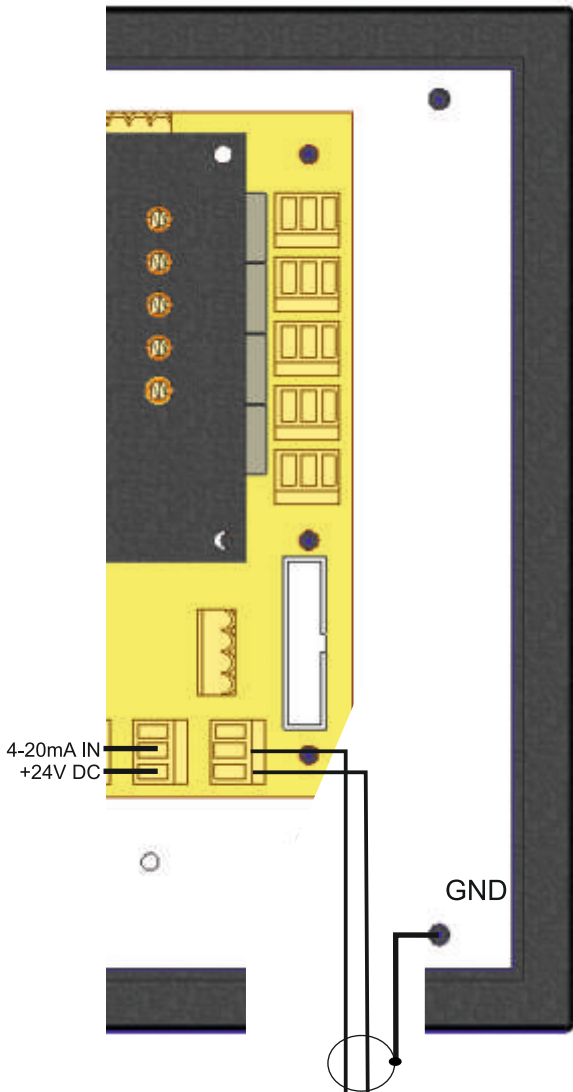

FIRE AND SMOKE INPUTS (FACTORY OPTION)

NOTE THESE DETECTORS ARE RESET BY INTERRUPTION OF THE POWER SUPPLY. THE TOCSIN 700 WILL DO THIS IF THE CHANNEL IS SELECTED AS A 'FIRE' AS A GAS TYPE, RELAY OUTPUTS MUST BE SET AS LATCHING. NOTE THAT THE POWER IS SUPPLIED TO THE INPUT CONNECTORS IN BANKS OF FOUR. IF MIXING WITH GAS DETECTORS SEGREGATE THE FIRST FOUR INPUTS AS GAS DETECTORS AND THE SECOND FOUR INPUTS AS SMOKE DETECTORS.

THIS IS A FACTORY FIT OPTION AND MUST BE REQUESTED WHEN ORDERING THE CONTROL PANEL. CHANNEL HARDWARE CONFIGURATION IS DIFFERENT TO STANDARD 4-20mA INPUTS

INTERFACING TO FIRE AND SMOKE DETECTOR DIODE BASES.

NOTE IF SUPPLIED IN THIS FORMAT THE INPUT CONNECTORS INCORPORATE PROTECTION DIODE. DO NOT USE WITHOUT THIS CONNECTOR/DIODE ASSEMBLY

NOTE LAST DEVICE IN LINE TO BE FITTED WITH 5K6 RESISTOR AS INDICATED

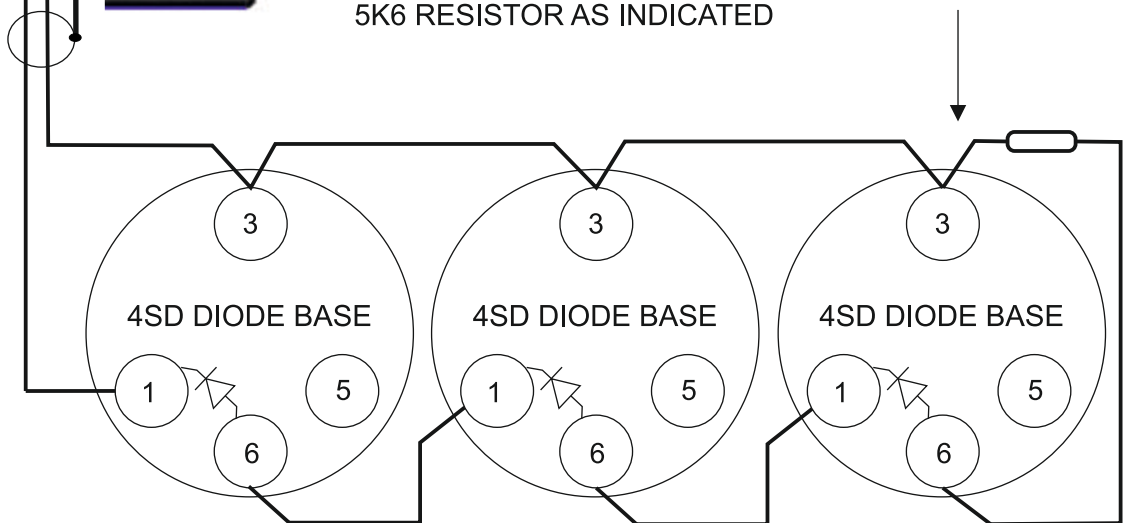

NOTE: TYPE INDICATED IS TYPICAL OF NITTAN ST-I CONVENTIONAL OPTICAL SMOKE OR HEAT DETECTORS. OTHER MANUFACTURER CONNECTIONS MAY VARY.

Tocsin 700 Interface wiring...continued, Addressable Systems.

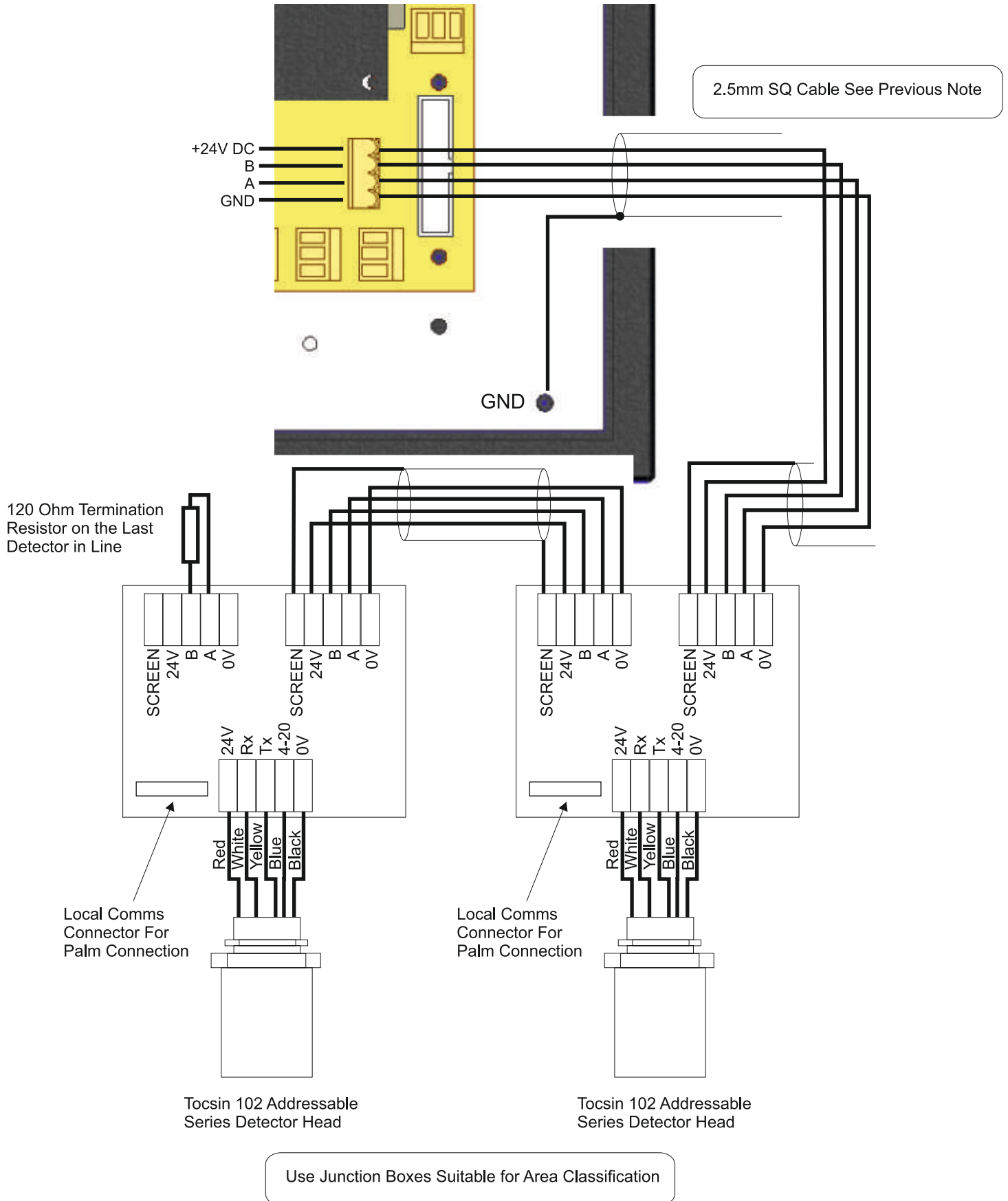

Tocsin 700 Interface wiring...continued, Addressable Systems Cont.....

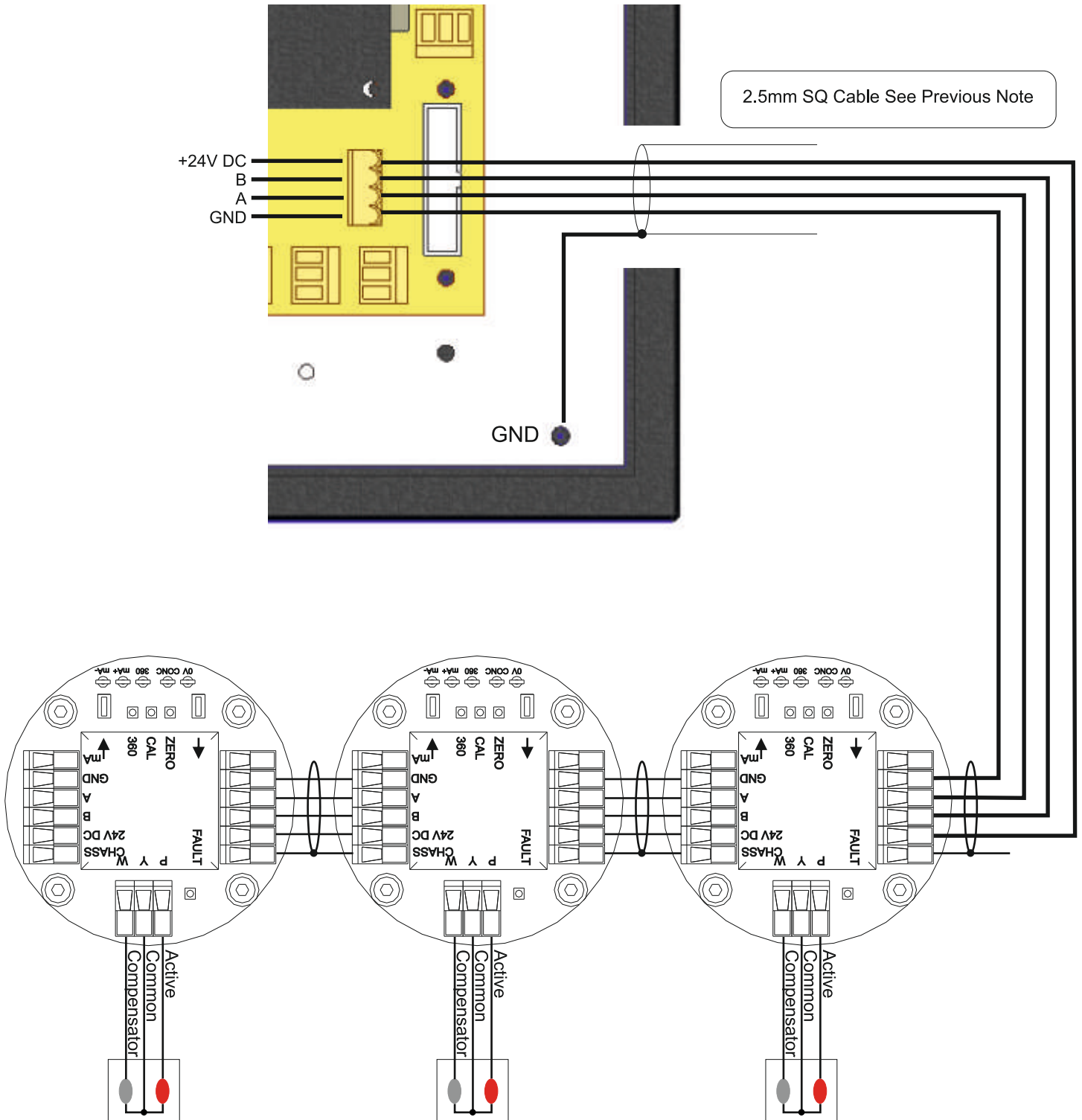

Use Junction Boxes Suitable for Area Classification

Tocsin 700 Interface wiring...continued, Addressable Systems Cont.....

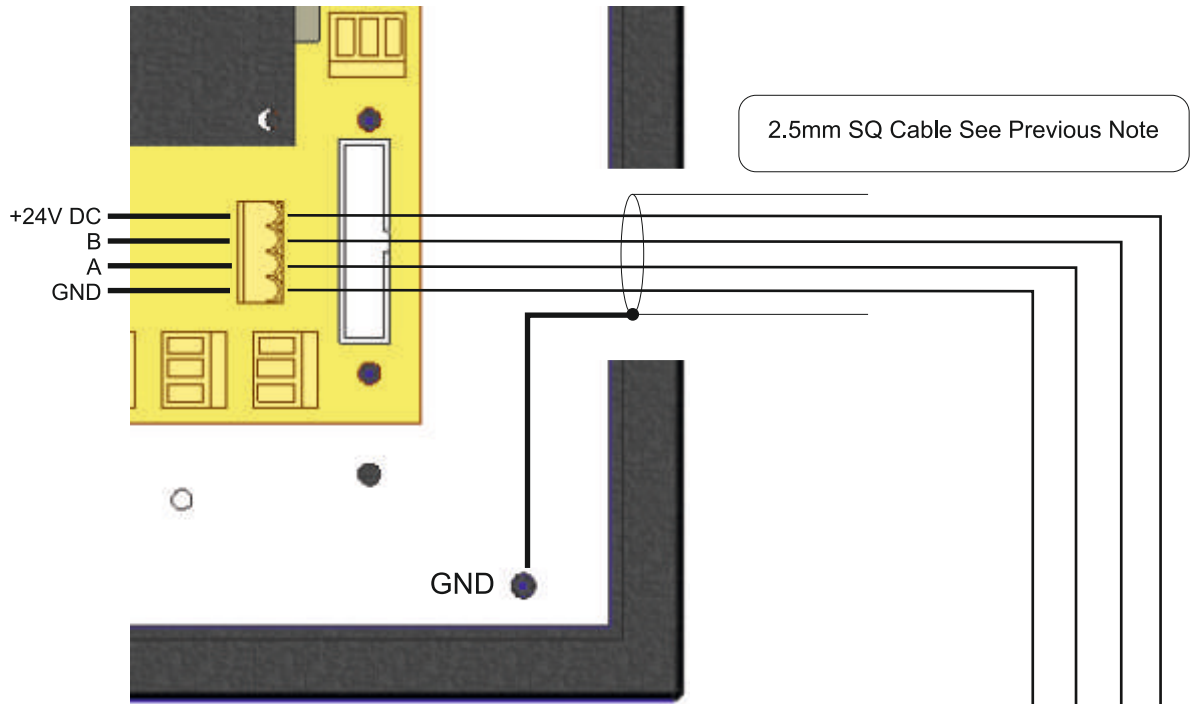

Addressable Relay Outputs

These come equipped with two volt free contacts which can be set as normally open or normally closed action

Use for beacon/sounders etc

Mix on the same loop as addressable detectors

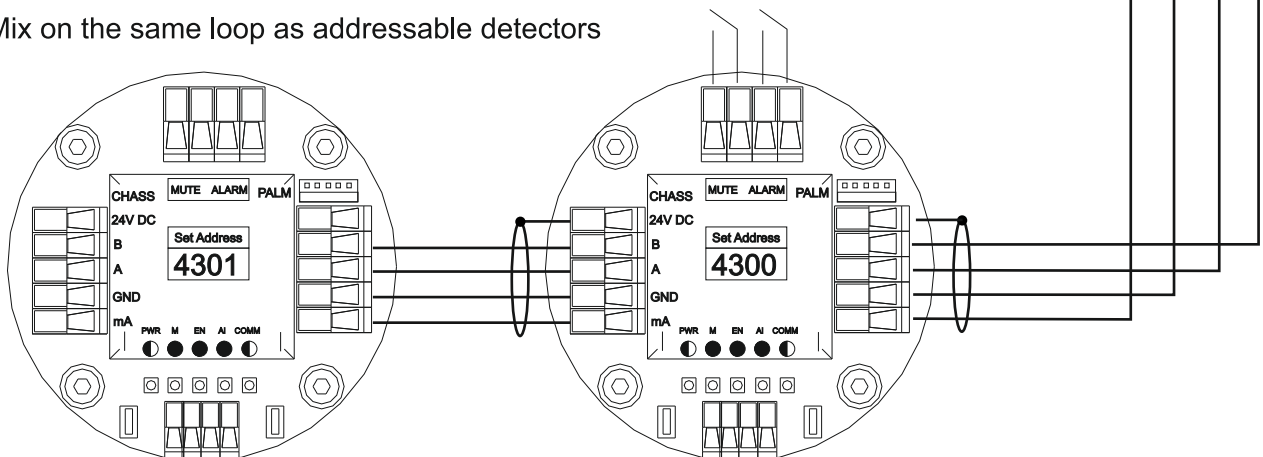

Use Junction Boxes Suitable for Area Classification

19" Rack Mount systems

Tocsin 700R 19" rack versions of the control panel are 24V DC powered and only interface as addressable systems. The systems are shipped with an addressable relay card mounted to the rear which can be remote mounted if required. Note that detectors are connected via the relay card connector shown below.

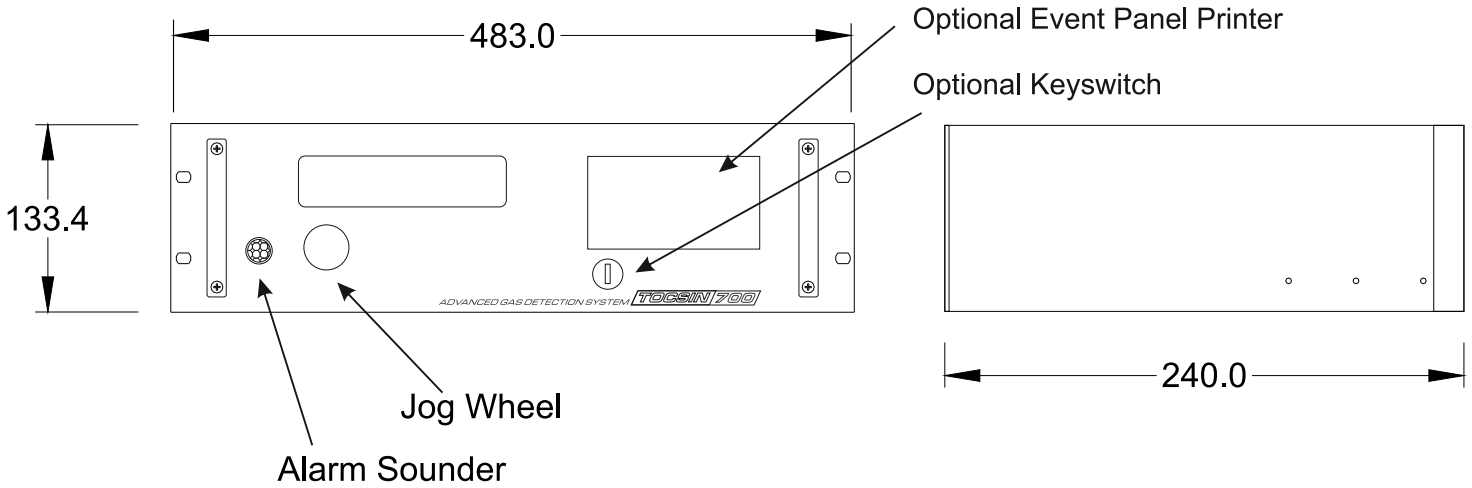

External Addressable Relay Card

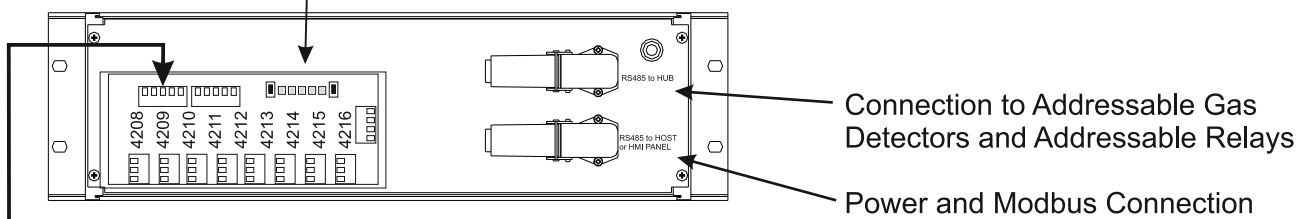

Detector Connector:	
Pin 1	24V DC
Pin 2	Comm B
Pin 3	Comm A
Pin 4	0V DC

Power Connector:		Cable
Pin 1	Comm B	Grey
Pin 2	Comm A	Green/Yellow
Pin 3	24 V DC	Brown
Pin 4	0V DC	Black

Addressable Gas Detectors and Addressable interface modules connect here in the same manner described previously.

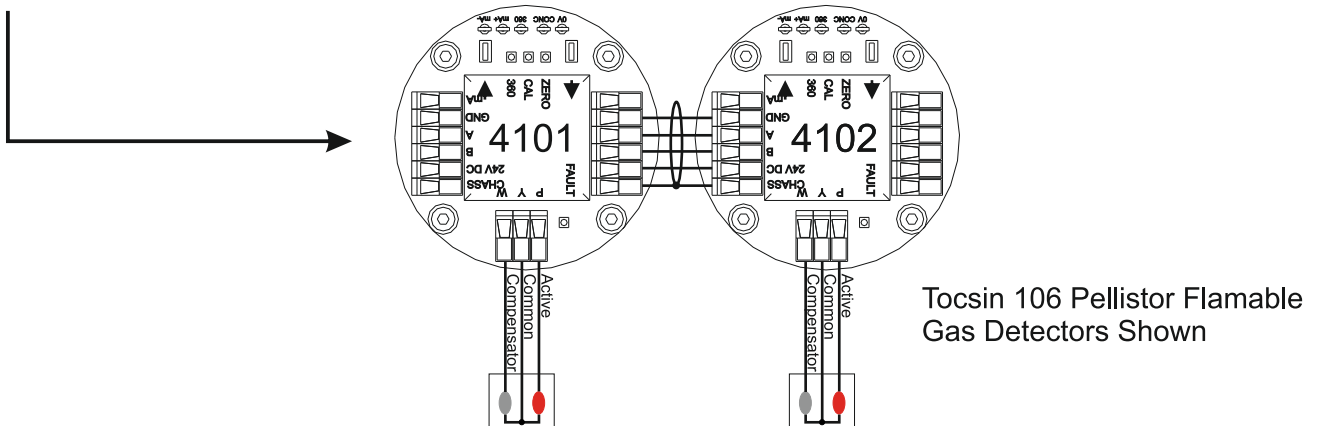

Addressable Relay Card

In all Cases:
 Relay contact ratings.
 7A @ 250V AC Non-Inductive
 7A @ 30V DC Non-Inductive
 Spike suppression diodes fitted
 Note that FAULT relays are normally energised on power up.

Power out for use in conjunction with relays
 0V DC
 24V DC

Relay status LED, ON when Energised

Base Address set up LED's and interface for the relay card

Highways Connection

Pin 1	0V DC
Pin 2	Comm A
Pin 3	Comm B
Pin 4	24 V DC

Pin 1	0V DC
Pin 2	Comm A
Pin 3	Comm B
Pin 4	24 V DC

Highways Connection

Normally Closed
Common
Normally Open

Relay Terminals

First Relay on The Card (relays number from this one).

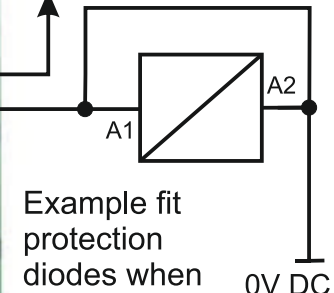
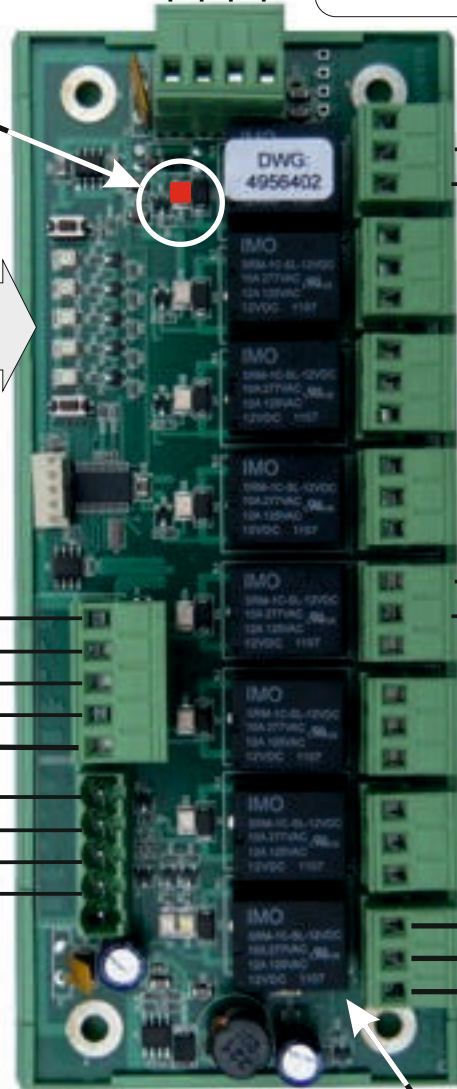

Example fit protection diodes when switching external DC loads.

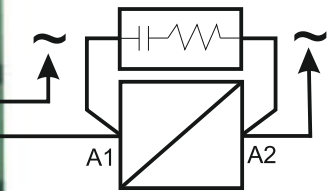

Example fit protection supressors when switching external AC loads typical device Farnell Ref 1438460

TOCSIN i700 Relay Outputs

There are four relays directly fitted to the Tocsin i700 controller. These can be configured by the user to activate on different alarm levels. One of the relays, is a dedicated system fault relay. See later programming details regarding alarm and fault relays.

Switching DC Loads

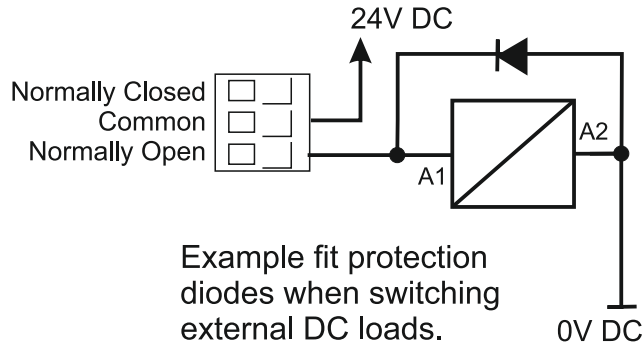

In all Cases:

Relay contact ratings.

7A @ 250V AC Non-Inductive
7A @ 30V DC Non-Inductive

Spike suppression must be fitted

Note that FAULT relays are normally energised on power up.

Switching AC Loads

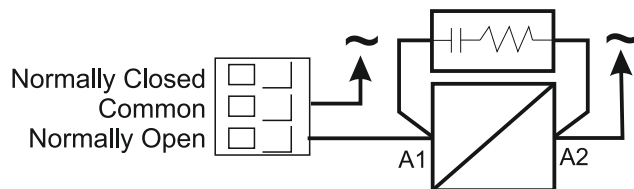

In all cases switched loads should have appropriate EMC protection as indicated in the diagram above. Loads should be fused. DC inductive loads should not be powered from the controller PSU. Inductive loads such as solenoids or motors can have high in-rush currents well above the steady state current indicated on data sheets. These high in-rush currents can interfere with the correct operation of the controller and so powering from the control panel is to be avoided.

Powering Third Party Devices

In general third party devices should only be switched and NOT powered from the Tocsin 700, (with the exception of beacons and sounders).

The Tocsin 700 controller has been extensively third party tested to ensure electrical safety and EMC compliance in a number of installation formats.

Connecting third party devices which may place unknown power demands on the Tocsin 700 can result in damage and/or unintended operation and so is NOT recommended.

The requirement to power gas shut off solenoid valves is common and so has been tested. The following tables and wiring arrangement will allow a suitable solenoid to operate correctly from the control panel.

Note this connection is direct from the 700 PSU. Incorrect connection can damage the 700 and power supply. Check polarity before powering

Example fit protection diodes when switching external DC loads.

Tocsin 700 Model	Max Solenoid Load @ 24VDC
60W PSU Version with 8 Detectors	1.5A
150W Version with 50 Detectors	1.5A

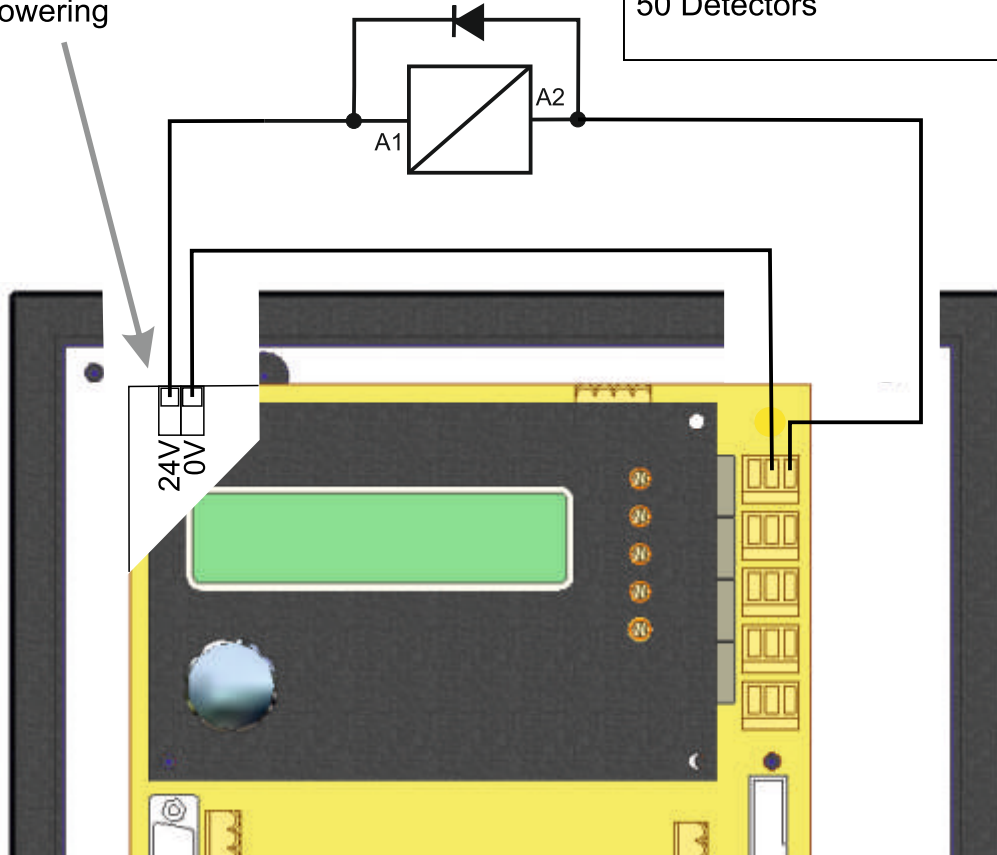

Do not exceed the ratings listed on this data sheet. Also note that some solenoid valves can have significant in-rush current which may adversely affect operation and overload the power supply.

Operating System

Operating System Overview

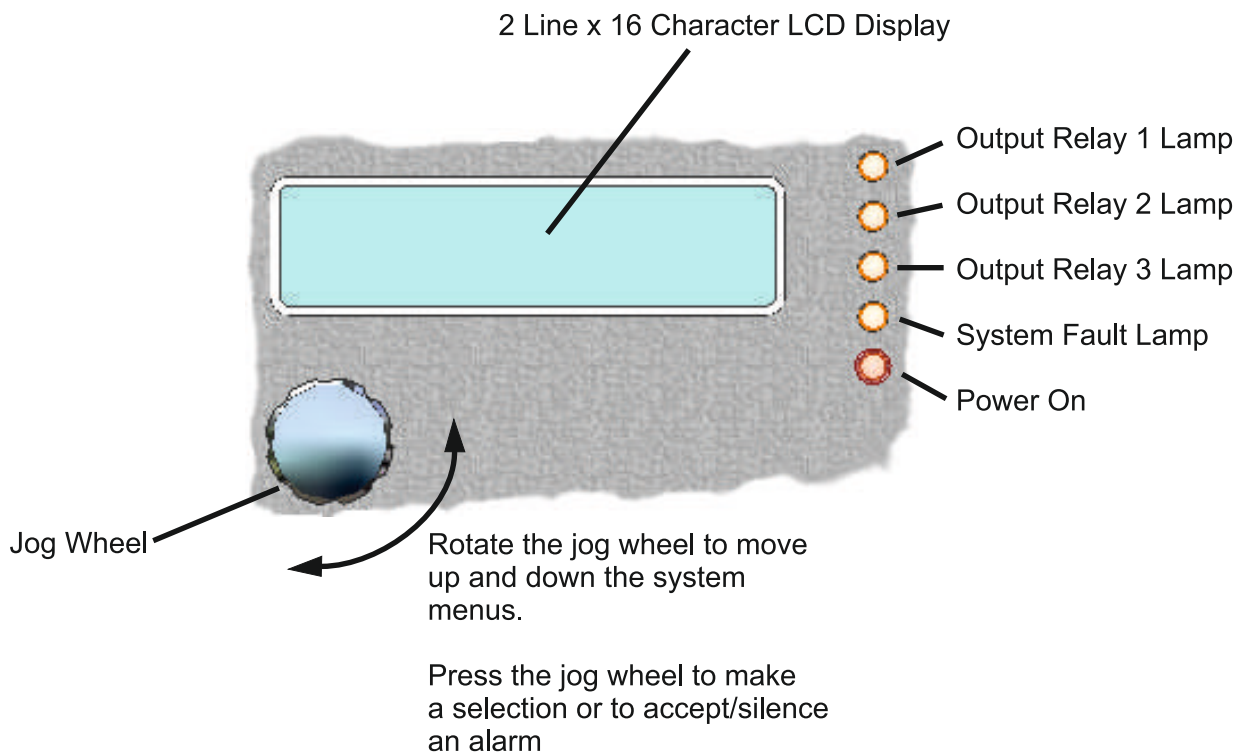

The Tocsin 700 series gas detector control panels are designed to be as flexible in operation as possible. The system software allows the owner/installer to configure the following functions:-

Configure input type, not only the selection of pre-programmed input gases but also the option to define an input type and scale the incoming 4-20mA signal to match. For example, pressure, temperature, distance etc

Decide alarm levels for each input and decide, rising, falling or latching alarms and which relay to assign to which inputs to allow, zoning etc

Logical naming of inputs, for example 'boiler 1' (max 8 characters)

Set the display scan rate

Zero and calibrate each channel from the control panel.

In addition the Tocsin 700 control panel can be 'hooked up' to a PC or PALM device via its serial programming link to allow system configuration using Oliver IGD software. This allows not only pre-configuration of the panel prior to commissioning but also a record of how the system was set up.

+Always refer to the shipping manifest and test schedule for confirmation of the shipped configuration.

Accepting and Reseting Alarms

For most of its operating life the Tocsin 700 control panel and associated sensors will monitor for whichever hazard it is configured for. The only requirement from the plant operator is to have the system regularly calibrated, typically every 3 or 6 months depending on the nature of the gas hazard. This section describes what happens at the control panel should the system detect a hazard and go into alarm and how to accept the alarm and reset the control panel.

Step 1. The panel detects a gas hazard

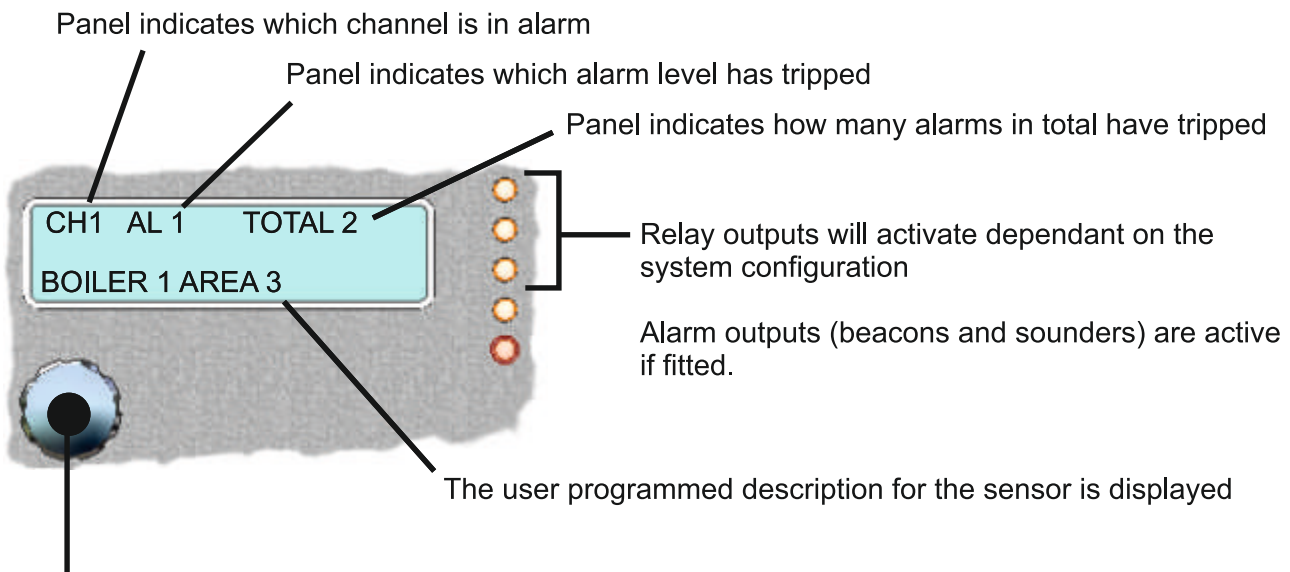

Step 2. Operator Accepts The Alarms

Pressing the jog wheel will accept the indicated alarm. If there is more than one alarm tripped then the next alarm is indicated on the display. Note that the total number of active alarms is indicated in the top right of the display.

Once all alarms have been accepted the sounder output from the panel is de-activated, if a sounder has been fitted it will silence. The relay outputs associated with the active alarms will still be energised until the gas hazard has been cleared and the panel reset.

Once all active alarms have been accepted the display will read as follows:

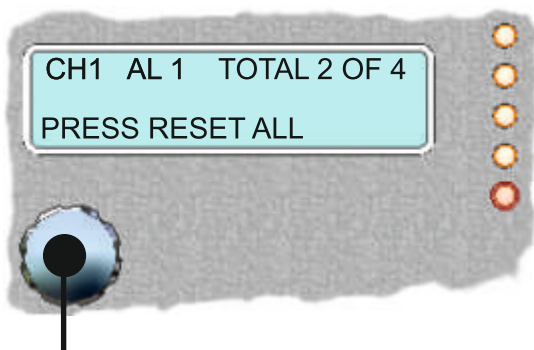

WARNING

It is important to have a site health and safety response in place in the event of alarm activation.

Gas detection systems are an indication that a problem may exist but should not be relied on as a failsafe system.

Pressing the jog wheel at this stage will reset the system. This de-activates any energised alarm relays depending on the panel user alarm programming and the 'beacon' output. If the gas hazard is still present then it will not be possible to reset the alarm.

Tocsin 700 Menu System

1. Start up

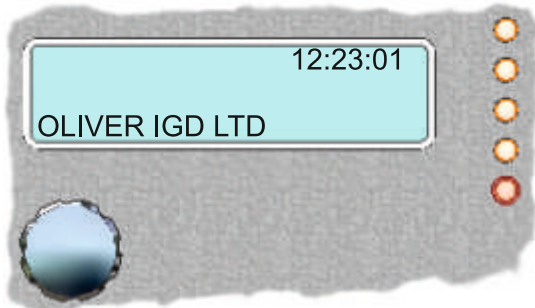

Time in 24 hour format.
Company name is programmable in EPROM Memory.

2. Warming Up

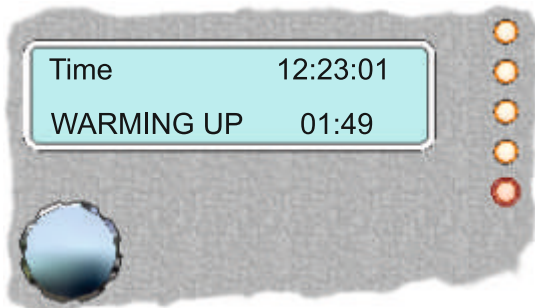

Warmup is displayed for the set period

3. Normal Display Mode

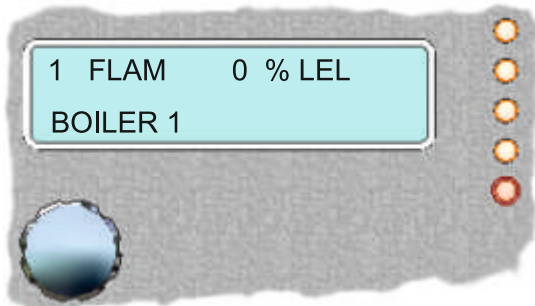

Normal display mode.
In normal display mode the display will auto scroll through all installed channels at a user settable time. The time is settable from 1 to 240 minutes.
Time is user programmable in seconds and is programmed in the engineering mode.

Normal display shows current channel in top left corner. Current channels measurement gas, reading and measurement units.

The gas types are pre-programmed in the Tocsin 700 operating system. 23 Gas Types are pre-programmed and a further 4 gas types can be added by the user.

There are three pre-configured measurement types.

%LEL PPM %VOL.

Again the user can add a further two measurement types.

4. Pre-configured Measurement Types

Display with %LEL (Lower Explosive Limit) Display

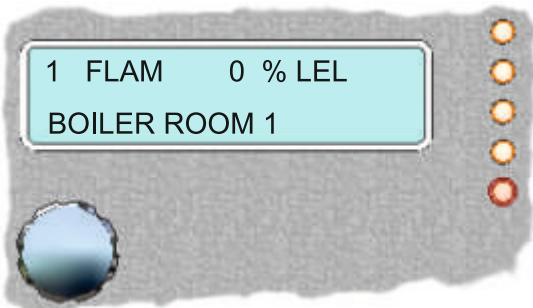

Display with ppm (Parts Per Million) Display

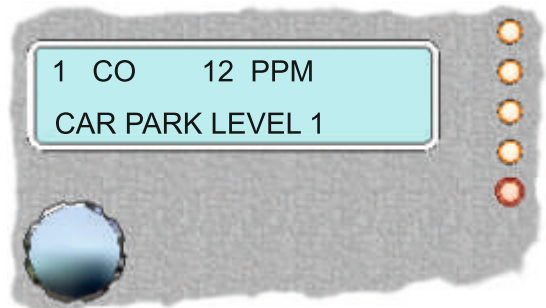

Display with %VOL (% by Volume) Display



The second line displays the channels description, up to eight characters long this is editable using the Tocsin 700 menu system.

5. Menu System

The menu system is accessed by firstly selecting a channel. This is done by rotating the Jog Wheel. Clockwise increases the channel indicated. Anti clockwise decreases the channel indicated. When the switch is rotated the back light illuminates and the unit stops it's auto scrolling function. If no channel is selected or if the button is not rotated within a minute then the unit returns to it's normal auto scrolling mode. In auto scrolling mode each channel fitted to the control panel is sequentially displayed for a fixed time period.

To select a channel to work on the Jog Wheel is pressed. This takes the user into the main menu. The channel selected is shown on the top line. This information updates with the users commands. The gas concentration also updates in this mode, this aids the user in calibration.

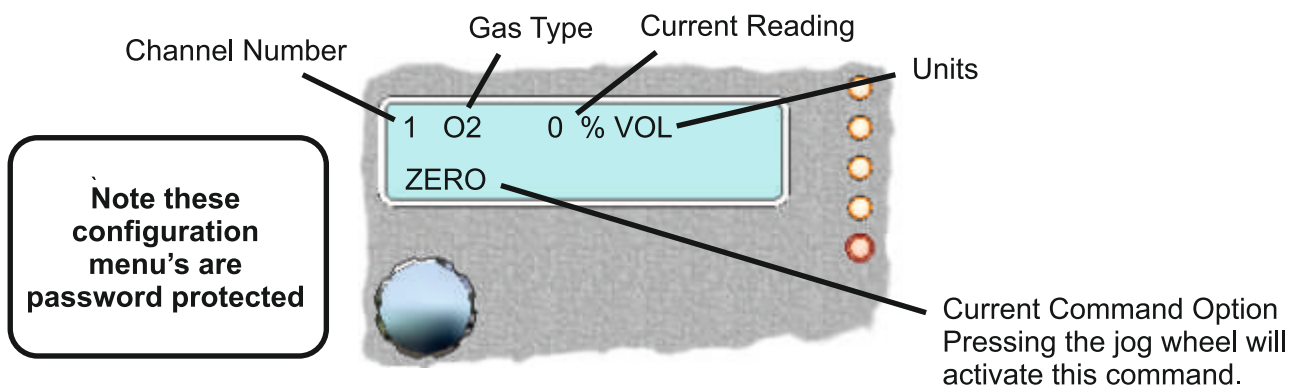

7. Menu System Overview Setup Menu's (User Menu)

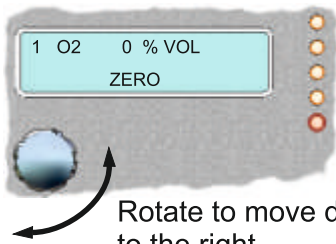

Press and hold down the jog wheel. The system will request a password. Once entered correctly the following menu sequence will be displayed.

Rotate to move down a menu. Pressing the button selects the sub menu one column to the right

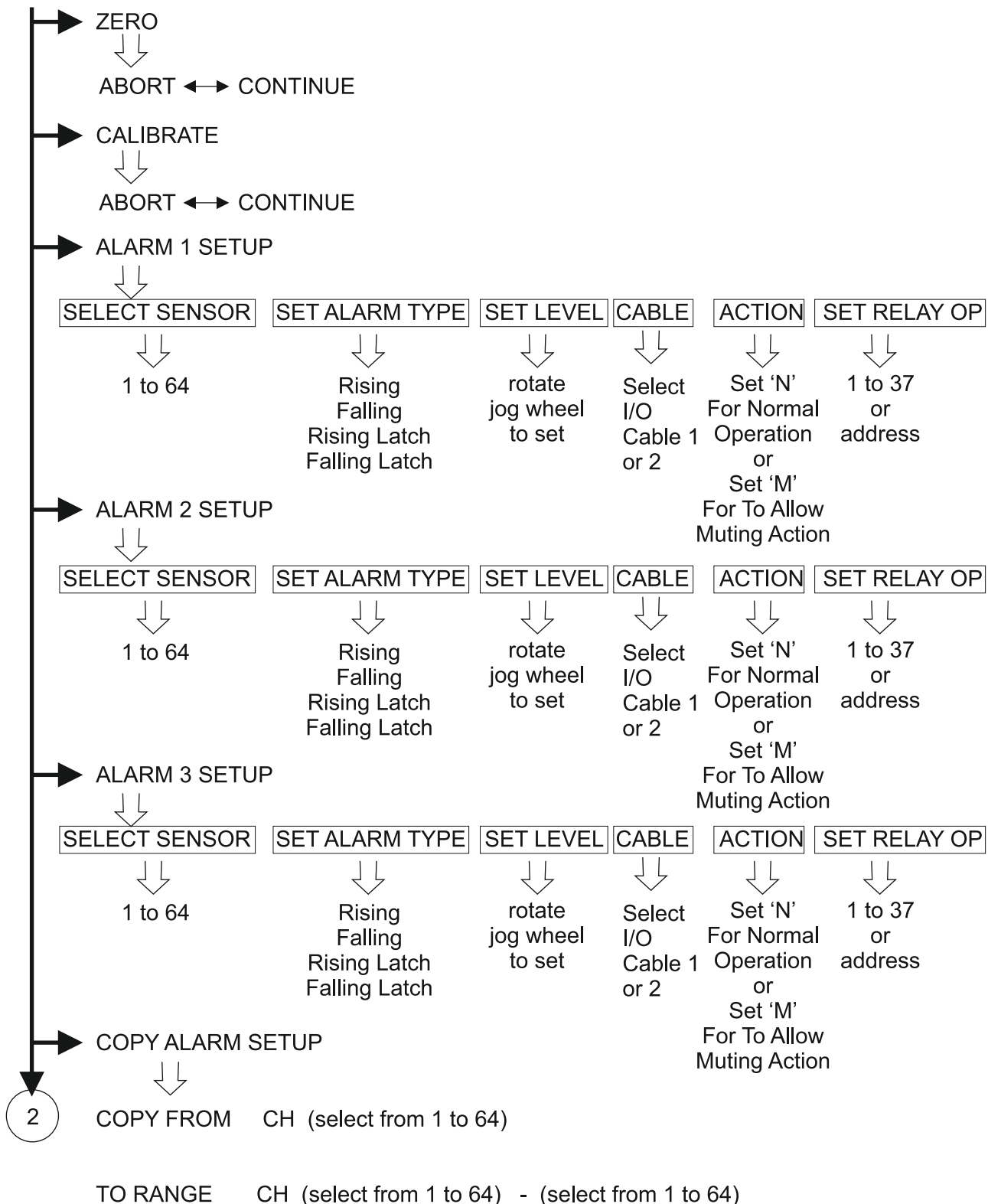

7. Menu System Overview Setup Menu's Continued

2

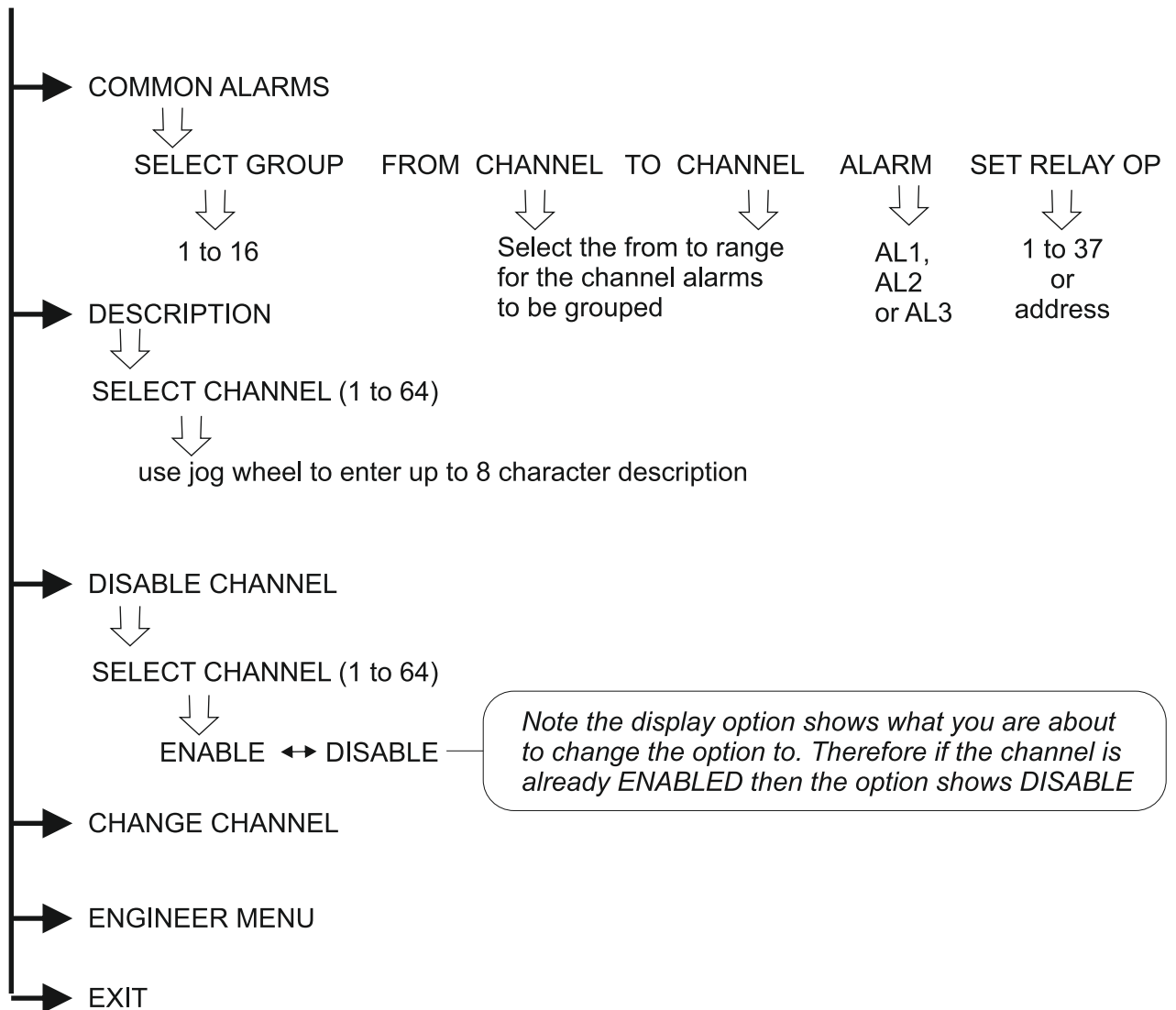

The bottom line of the display shows the command available for selection and is altered by rotating the jog wheel.

5.1 The Zero Command

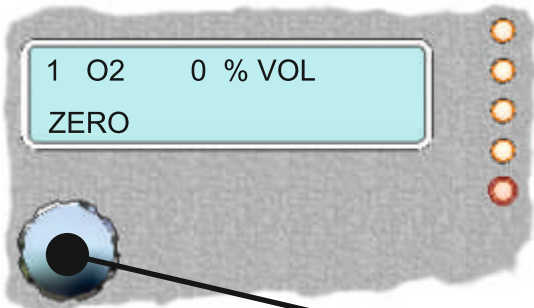

With the panel in normal display mode, rotate the jog wheel to the desired channel and press the jog wheel. Now rotate the jog wheel until the bottom line of the display reads zero. At this stage apply zero gas to the gas head and allow the reading to stabilise.

Once the reading has stabilised press the jog wheel and the bottom line will change to read zeroing. The Tocsin 700 now averages the incoming signal for a few seconds before applying any necessary zero correction. Once complete the bottom line of the display changes to read 'PASSED' or 'FAILED'. If the zero operation passed the zero correction is applied.

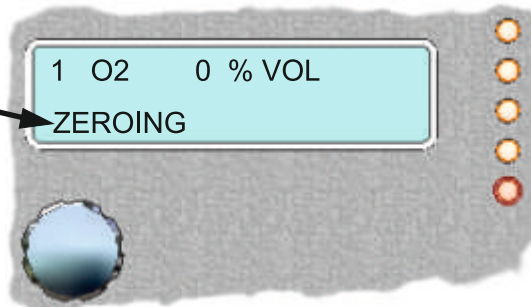

5.2 The Calibrate Command

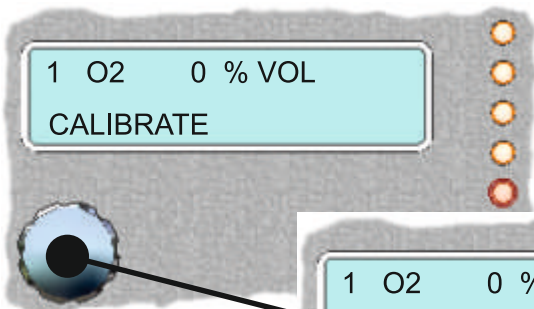

This function allows the user to calibrate a channel. As in the case of the zero function, select a channel to be calibrated and rotate the jog wheel until the 'Calibrate' option appears on the bottom line of the display.

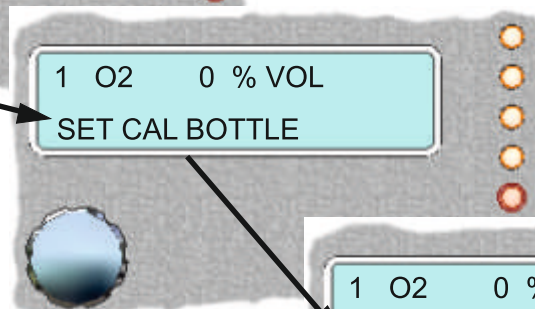

The display set bottle will appear for a few seconds to prompt the input of the calibration gas set point.

The bottom line of the display now changes to allow the input of the calibration gas value. The display will indicate the last value used to calibrate the channel. Rotate the jog wheel:

Clockwise to increase the value.
Anticlockwise to decrease the value.

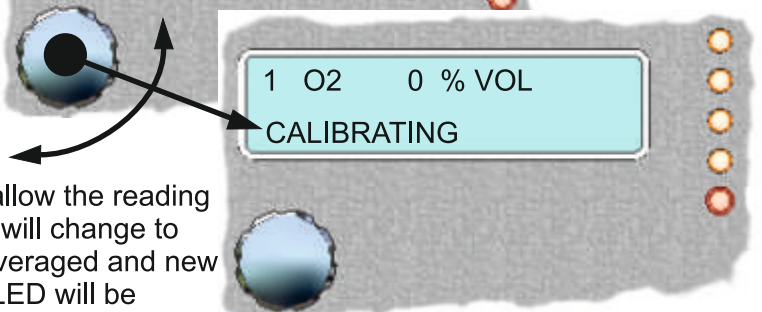
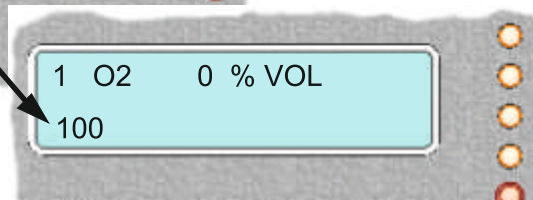

With the calibration gas applied to the gas head allow the reading to stabilise then press the jog wheel. The display will change to 'calibrating' for a few seconds as the reading is averaged and new calibration constants calculated. PASSED or FAILED will be displayed and once complete the display will return to step A.

5.3 Set Alarm Level Setup for Alarm Levels 1,2 and 3

Select the ALARM 1 SETUP from the user menu. And the following display will be shown. Note you are now editing alarm level 1 settings. By changing the channel number you can check and set all alarm level 1 settings for each channel connected. Press and hold the jog wheel to exit the screen then select ALARM 2 and ALARM 3 SETUP's.

As you enter this menu screen the channel number will be flashing.

Press the jog wheel to move sequentially around the screen.

With the item you want to change flashing rotate the jog wheel to alter levels or options.

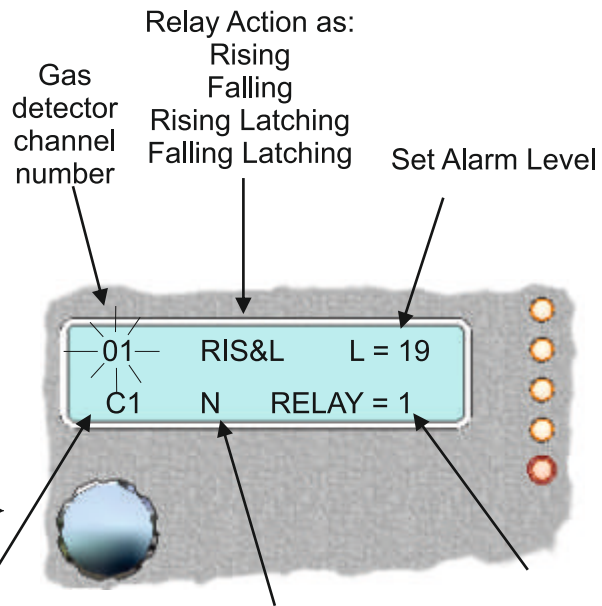

Cable Number (1 or 2) For Addressable Detectors and Relays. Note this is not relevant for Analogue Detectors or On-board Relays

Relay Action. Set as N for Normal Operation or Set as M if you want the relay to De-activate when the jog wheel is pressed to Mute an active alarm, Mute Action

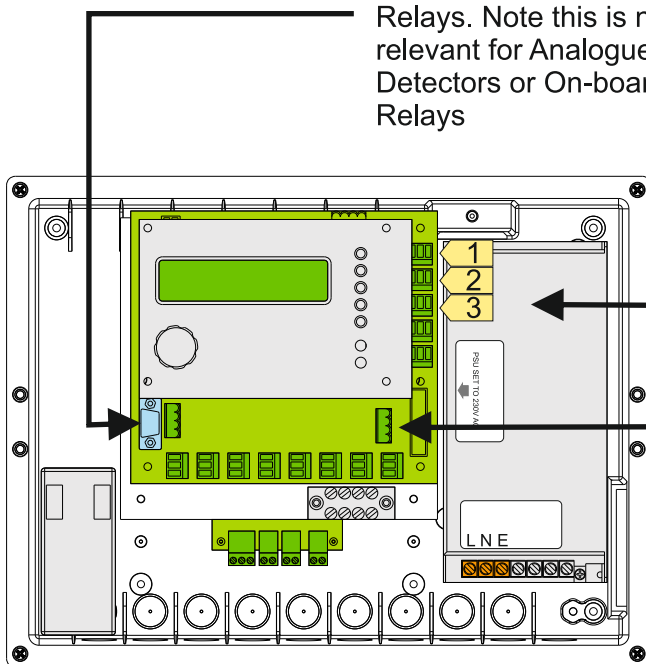

Relay Number To Activate When Alarm Level Exceed

Note relay numbers 1 to 3 are included on the main panel located as shown here

Relay outputs can also be added onto the addressable highway along with gas detectors to provide local relay outputs for sounders/beacons and small solenoids etc.



These outputs start their numbering from 4201. Up to 32 addressable relay output nodes can be added to either addressable cable 1 or 2 (C1,C2).

This example shows an alarm set once 50ppm is exceeded on channel 01. The relay activated if this occurs is on the addressable highway at address 4201 connected to port 1 (C1). The alarm is Rising and Latching in operation and so must be manually reset at the Tocsin 700 panel (RIS&L). If the T700 jog wheel is pressed the alarm will Mute (De-activate) as the action is set to M.

Copy Alarm Setup Command

Select the COPY ALARM SETUP if you want to copy the complete alarm setup from one channel to multiple others. This can be used to speed setup where there are many sensors/channels that are to have the same alarm levels set. Each channel can then have any minor amendments made after copying the majority of the setup thus speeding up the setting up process of the control panel.

1

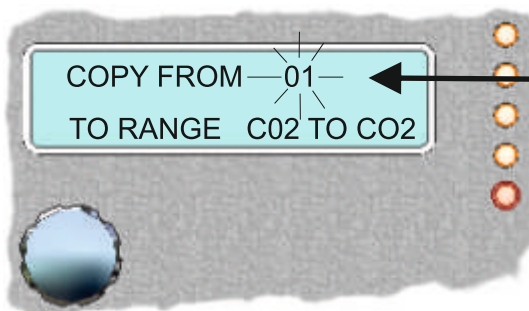

Select the COPY ALARM SETUP menu item and the following setup screen is displayed.

Note the COPY FROM channel number is flashing. This is the channel whose setup you wish to copy to other channels. Rotate the jog wheel if you wish to select a different channel to be copied from. Once the selection is correct press the jog wheel.

2



The first of the copy to channel numbers is now flashing. Again rotate the jog wheel until the first channel number in the range you wish to copy to is displayed. Press the jog wheel when the first channel in the range to copy to is indicated.

2

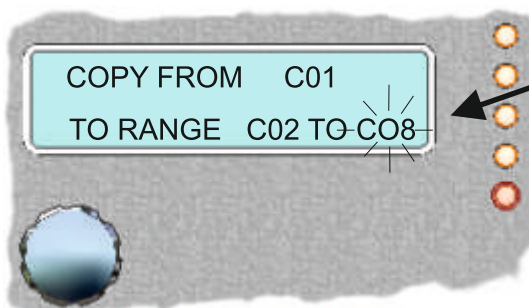

The second of the copy to channel numbers is now flashing. Again rotate the jog wheel until the last channel number in the range you wish to copy to is displayed. Press the jog wheel when the last channel in the range to copy to is indicated.

In this example the alarm setup from channel one will be copied to channels two through eight.

5.6 Editing The Channel Description

Select DESCRIPTION from the user menu. This allows the user to edit the description shown when the unit is in normal display mode. This description is also used in Alarm indication to show alarm locations.

Rotating the jog wheel causes the current character to change. Once the desired character is displayed press the jog wheel to accept it and move on to the next character to be edited. Once the desired text string is complete press and hold in the jog wheel. The display will flash to indicate the end of text edit mode. Release the jog wheel and the newly edited text string is accepted.

5.7 Change Channel

Allows the user to change channel being edited. This allows the user to stay in the menu system rather than going out and coming back in. Press the jog wheel until the desired channel number is displayed. Press the jog wheel to then move to that channel.

5.75 Common Alarms

This function allows the alarm activation of a relay output from a number of grouped channel alarms (AL1,2 or 3).

Common Alarm group Number up to 16 groups can be stored

Alarm Level for the range of selected channels

Range of channels Selected

Relay Output (in this example an addressable relay output)

In this example for common alarm group 1 any Alarm level 1 that activated for channels 1 to 6 on the control panel will activate relay output 4201 (this would be an addressable relay output in this instance).

Note relays used in grouped functions should ideally not be used elsewhere in the setup for individual alarm outputs.

5.8 Common Alarms

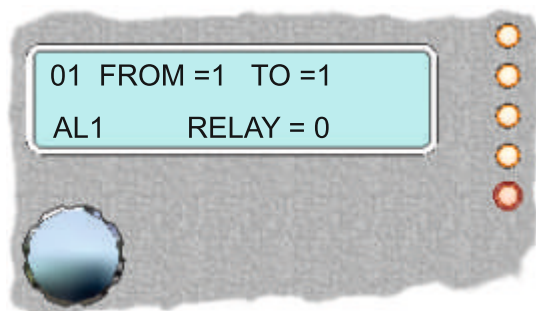

The common alarm menu provides another method to activate alarm outputs. The menu option provides a method to 'group' together channel alarms to a common alarm output.

As an example if channels 1 to 6 on the control panel all need to activate a beacon sounder on first alarm: then this is simpler to set using the common alarms menu rather than programming on each channel alarm.

This also free's up the channel alarms for other outputs.

When using common alarms there are some restrictions to bear in mind when planning both the layout of the channels and alarms:

- 1: Common alarms work best with consecutive channels so if there is a requirement for a common alarm output to work with a number of detectors in an area, make sure the detectors are on consecutive channels.
- 2: If you use a relay output on a common alarm DON'T also use that relay on a normal channel alarm. doing so runs the risk that a channel in the common alarm group can be trying to 'set' a relay whilst an individual normal channel alarm can be trying to reset the same relay. This can result in unpredictable alarm operation and is to be avoided.
- 3: There are 16 common alarms
- 4: If using addressable relay outputs or nodes, these must be on Cable Highway 1

Programming Example

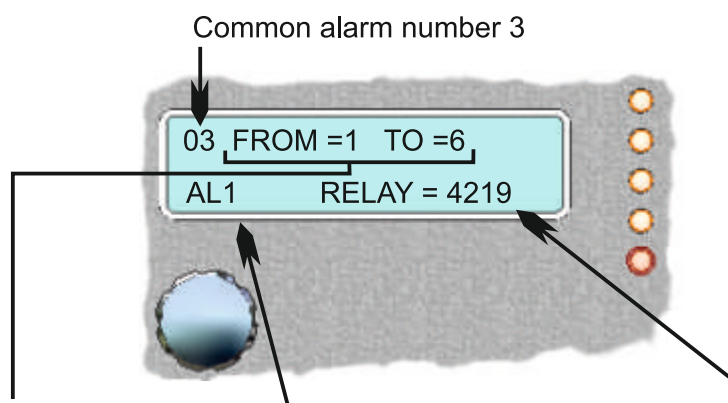

From channel 1 to channel 6 any AL1 on these channels activates addressable relay 4219

5.9 EXIT

Returns user to normal display. Auto scrolling initiates and back light turns off after 1 minute.

8. Menu System Overview Engineers Menu

→ CHANNEL SETUP

↓ ↓

CHANNEL SELECT 1 TO 64	GAS SELECT	RANGE	UNITS	CABLE	TYPE	ADDRESS
	↓ ↓	↓ ↓	↓ ↓	↓ ↓	↓ ↓	↓ ↓
	FLAM	CUST	%LEL	Select	102	1 TO 16 For
	CO	1	PPM	I/O	102IR	analogue inputs
	NO	5	%VOL	Cable 1		4100 to 4200
	NO2	10		or 2		For Digital
	CL2	25				Inputs
	HCL	50				
	HCN	100				
	NH3	200				
	O2	500				
	H2S	1000				
	SO2	2000				
	H2	3000				
	O3					
	CO2					
	FIRE					
	CFC					
	VAC					
	PRES					
	TEMP					
	HF					
	EthO					
	SiH4					
	BCL3					

→ COPY CH SETUP

↓ ↓

COPY FROM CH (select from 1 to 64)

TO RANGE CH (select from 1 to 64) - (select from 1 to 64)

→ FIND ADD SENSORS

↓ ↓

EDIT LOW ADDRESS (enter start address)

EDIT HIGH ADDRESS (enter end address)

→ FIND ADD RELAYS

↓ ↓

Reports which cables will be checked based on setting for Cable C2

2

↓ ↓

Found = 4
1 of 4 = 4201 (C1) ——— Each jog wheel press shows the next found relay. Note the cable number its is found on is also reported. This function is for information only.

2

→ SENSOR DIAG
 ↓↓
 rotate jog wheel to select sensor/channel
 ↓↓
 press jog wheel to view
 CONCENTRATION → mA → ZERO CAL BOTTLE RANGE

→ SENSOR ADJUST
 ↓↓
 SELECT CHANNEL (1 to 64)
 ↓↓
 SELECT TO ADJUST ZERO AND SPAN GAIN
 OF A DETECTOR. (Addressable detectors only)

→ ZERO ALL SENSORS

→ CHANGE ADDRESS
 ↓↓
 WARNING ABORT OR CONTINUE
 ↓↓
 SET CURRENT ADDRESS (4100 TO 4200)
 ↓↓
 SET NEW ADDRESS (4100 TO 4200)

→ SET TIME
 ↓↓
 HOUR (rotate jog wheel to change press jog wheel when correct)
 ↓↓
 MINUTE (rotate jog wheel to change press jog wheel when correct)

→ SET DATE
 ↓↓
 DAY (rotate jog wheel to change press jog wheel when correct)
 ↓↓
 MONTH (rotate jog wheel to change press jog wheel when correct)
 ↓↓
 YEAR (rotate jog wheel to change press jog wheel when correct)

→ ADD CHANNELS

3

↓↓
 TEL FOR NEW SEED 42038 (contact Oliver IGD to obtain code to change the number of connected channels)

3

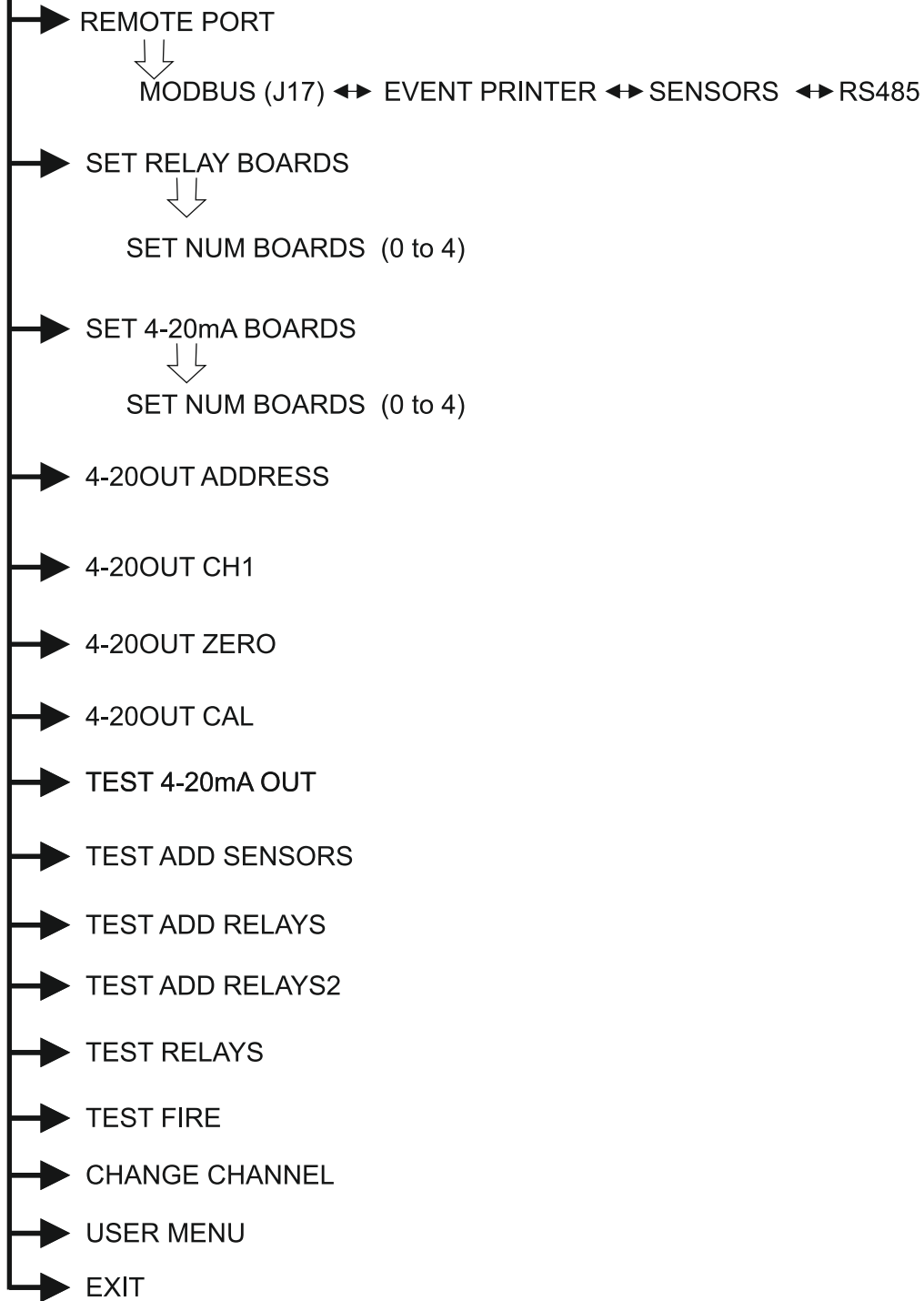

5.3 Detector Channel Setup

Select the CHANNEL SETUP from the ENGINEER menu. And the following display will be shown. By changing the channel number you can check and set all channels connected. Press and hold the jog wheel to exit the screen. Note that channels for addressable detectors will be automatically configured by using the FIND command (see later)

As you enter this menu screen the channel number will be flashing.

Press the jog wheel to move sequentially around the screen.

With the item you want to change flashing rotate the jog wheel to alter levels or options.

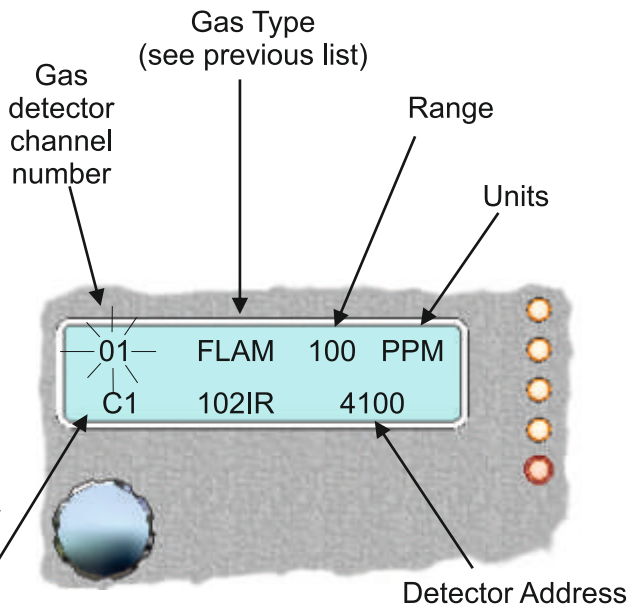

Cable Number (1 or 2) For Address. Note this is not relevant for Analogue Detectors.

Note address numbers 1 to 8 are included on the main base panel located as shown here

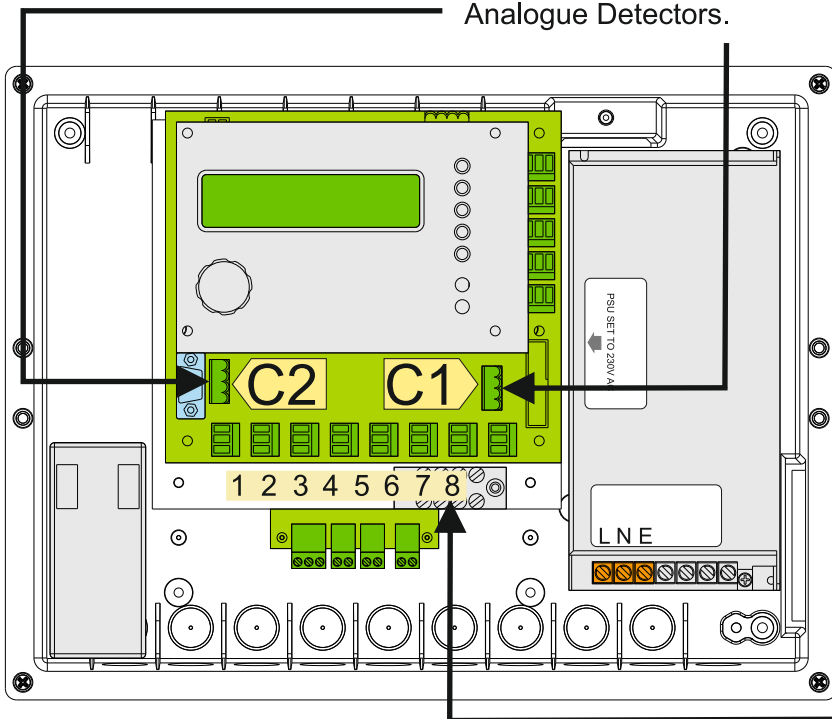

Digital addressable detectors wired to port C1 and C2 have addresses starting at 4100. Up to 32 detectors can be wired on each port.

As mentioned above, addressable detectors can be automatically installed by using the FIND command described later in this manual.

Analogue channels must be set up manually. The control panel accepts input from any 4-20mA device, not necessarily gas detectors. For flexibility the channel setup function allows the gas type, range and units to be configured. Most standard gas types, ranges and units can be selected from the pre-configured lists. However if the required gas type, range or units are not present on the pre-programmed lists then up to four user configurable types can be added. Adding user types is detailed later in this manual. Note that channel setups can be copied to speed set up in a similar manner to the way alarm setups are copied.

Copy Alarm Setup Command

Select the COPY CHANNEL SETUP if you want to copy the complete channel setup from one channel to multiple others. This can be used to speed setup where there are many sensors/channels that are to have the same detector inputs set and scaled. Each channel can then have any minor amendments made after copying the majority of the setup thus speeding up the setting up process of the control panel.

1



Select the COPY CHANNEL SETUP menu item and the following setup screen is displayed.

Note the COPY FROM channel number is flashing. This is the channel whose setup you wish to copy to other channels. Rotate the jog wheel if you wish to select a different channel to be copied from. Once the selection is correct press the jog wheel

2

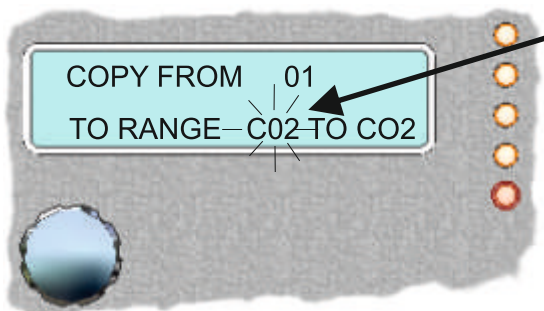

The first of the copy to channel numbers is now flashing. Again rotate the jog wheel until the first channel number in the range you wish to copy to is displayed. Press the jog wheel when the first channel in the range to copy to is indicated.

2

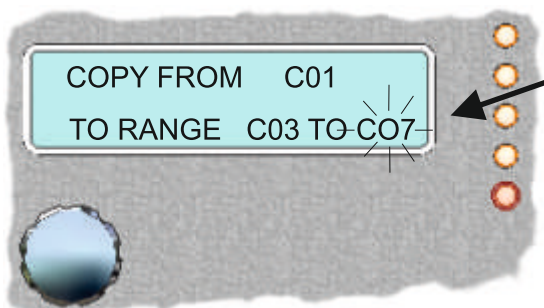

The second of the copy to channel numbers is now flashing. Again rotate the jog wheel until the last channel number in the range you wish to copy to is displayed. Press the jog wheel when the last channel in the range to copy to is indicated.

In this example the channel setup from channel one will be copied to channels three through seven.

The FIND Command

If addressable gas detectors are cabled to either port 1 or 2 of the control panel then the FIND command can be used to automatically install these detectors onto the panel. Note this option is usually only run the first time detectors are connected and will already have been run if factory configuration has been requested and undertaken. Running the FIND command again will overwrite any previously stored information. This will include any alarm level set up as a newly installed detector will have default alarm levels set automatically as part of the FIND function.

1

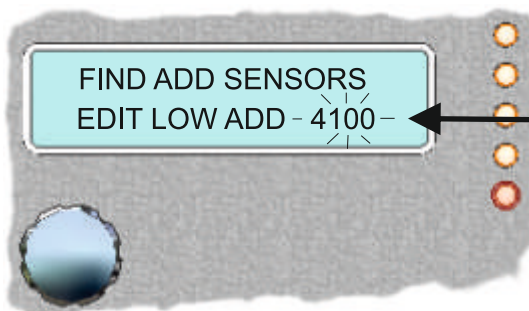

Select the FIND ADD SENSORS menu item and the following setup screen is displayed.

Use the jog wheel to enter the first address in the sequence you expect to find (usually 4100)

Note the low address number will be flashing. Once correctly set press the jog wheel to move to the next setting.

2

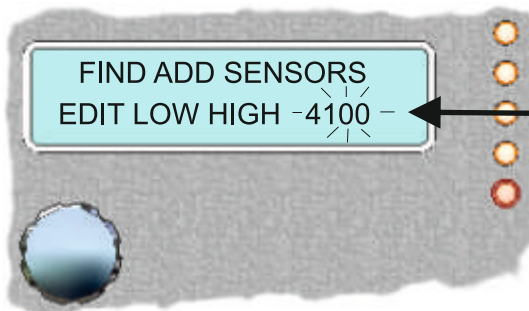

Now use the jog wheel to enter the highest address you expect to find. Once set press the jog wheel.

3



The system now checks through each possible address in the range selected and tries to communicate to each address in turn.

The top line of the display indicates the current address being searched for and the bottom line of the display shows the total number of detectors found so far

The FIND Command Continued.....

4

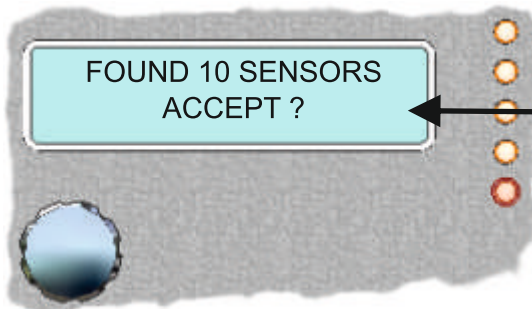

The system now advises how many detectors have been found. You now have the option to press the jog wheel and ACCEPT these detectors into the panel setup or select ABORT to exit the FIND option and make no changes

5

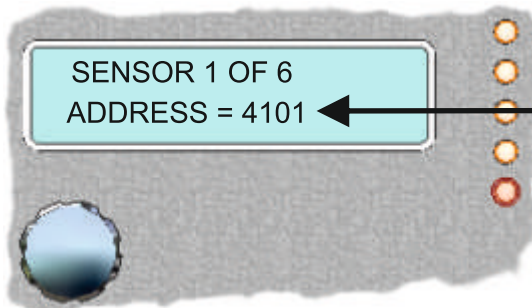

If you select to ACCEPT the found detectors the system will indicate sequentially each address that has been found. At this stage these should be noted down on a setup sheet to keep a record of which channel is which detector address. Press the jog wheel to display each detector address in turn.

The FIND ADD RELAYS Command

If addressable Tocsin 107 series I/O Nodes are cabled to either port 1 or 2 of the control panel then the FIND ADD RELAYS command can be used to check that the Tocsin 700+ can communicate to them. The function first checks if port C2 is set for SENSORS option, if not it is ignored. The function then interrogates the highways and reports how many addressable relays have been discovered and what addresses and cable numbers (C1 or C2) they are on.

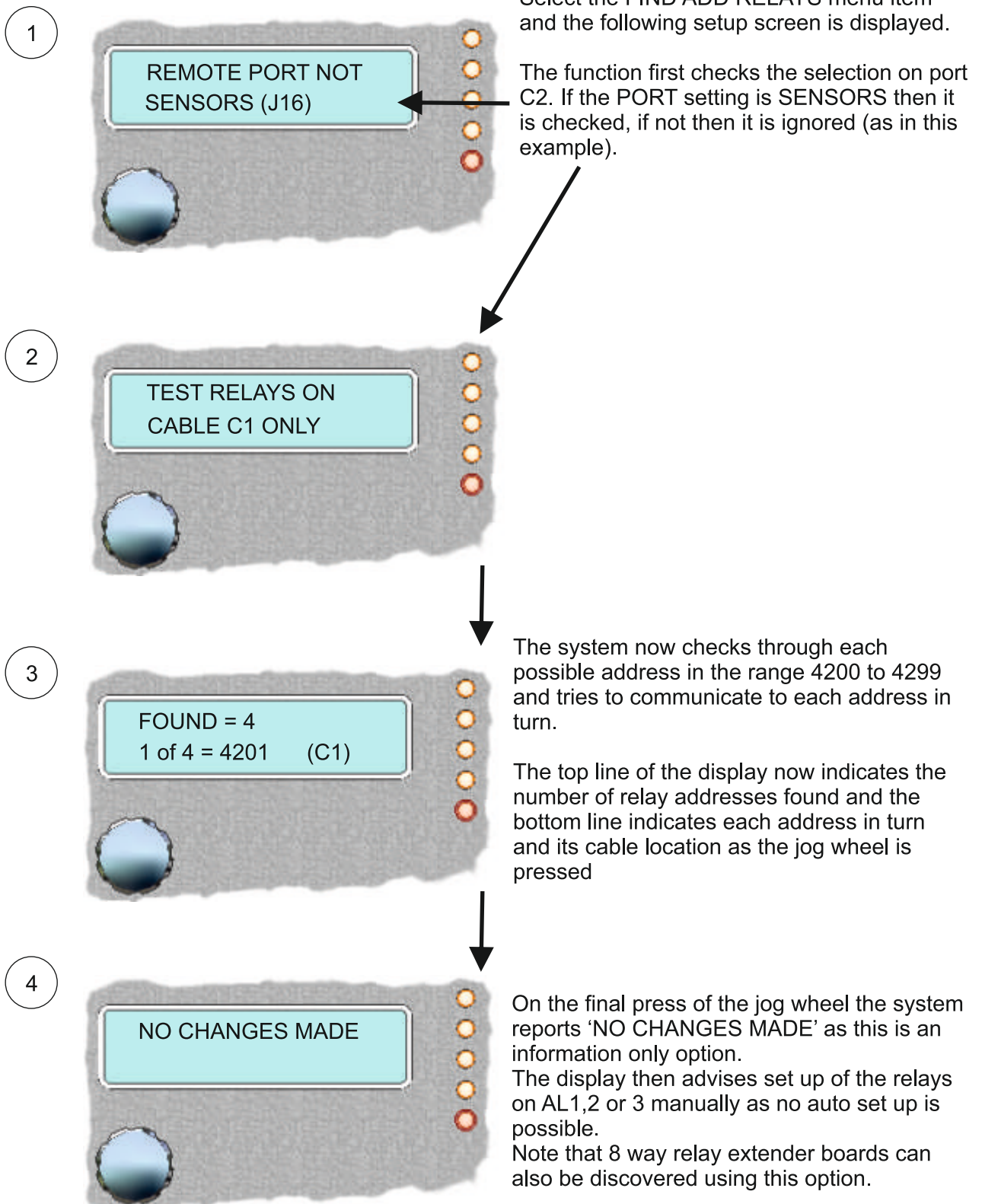

The TEST ADD SENSORS command

This function can be used to check correct communication is in place when commissioning or testing addressable gas detectors.

The top line of the display indicates the current channel under test. The system will step through each detector in turn. In this mode of operation the detectors are run 10 times faster than normal to exercise the communication circuits

The bottom line of the display shows the percentage of errors detected. Errors can be of two types. If a data packet is corrupt it will be discarded. If a detector takes too long to reply to a request for data then this will also be an error. Ideally for a newly installed system all channels will show zero errors. Greater than 0.5% errors indicates an 'electrically noisy' industrial environment or potentially faulty detector or cable terminations. Up to 0.5% errors can be tolerated. Normally errors can be traced to poor electrical terminations.

The TEST ADD RELAYS command

Similar to the TEST ADD SENSORS this function can be used to check correct communication is in place when commissioning or testing addressable relay output nodes.

The top line of the display indicates the current relay under test. The system will step through each detector in turn. In this mode of operation the detectors are run 10 times faster than normal to exercise the communication circuits

The bottom line of the display shows the percentage of errors detected. Errors can be of two types. If a data packet is corrupt it will be discarded. If a detector takes too long to reply to a request for data then this will also be an error. Ideally for a newly installed system all channels will show zero errors. Greater than 0.5% errors indicates an 'electrically noisy' industrial environment or potentially faulty detector or cable terminations. Up to 0.5% errors can be tolerated. Normally errors can be traced to poor electrical terminations.

NOTE

This test is a communications test only and does not power the actual relay outputs. To test the relays use the TEST ADD RELAYS2 function.

The TEST ADD RELAYS2 command

This function can be used to check relay operation when commissioning or testing addressable relay output nodes.

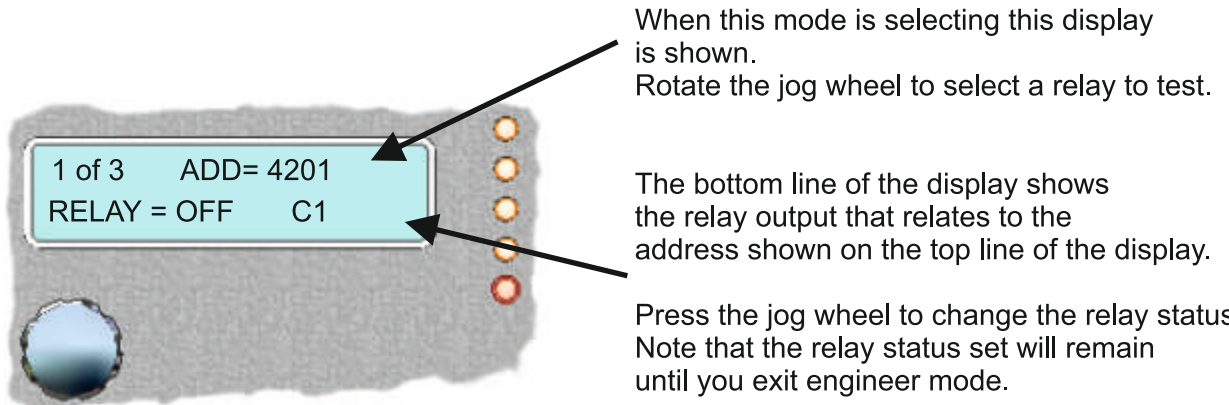

It should also be noted that the relay action (normally open or normally closed) is set on the Tocsin 107 module software. If a Tocsin 107 module is set as normally closed then switching it on here to test it will energise it to be normally open and vice versa.

The TEST RELAYS command

This function can be used to check relay operation for relays 1 to 3 on the Tocsin 700 and relays 4 to 36 on any add-on relay cards that may be present.

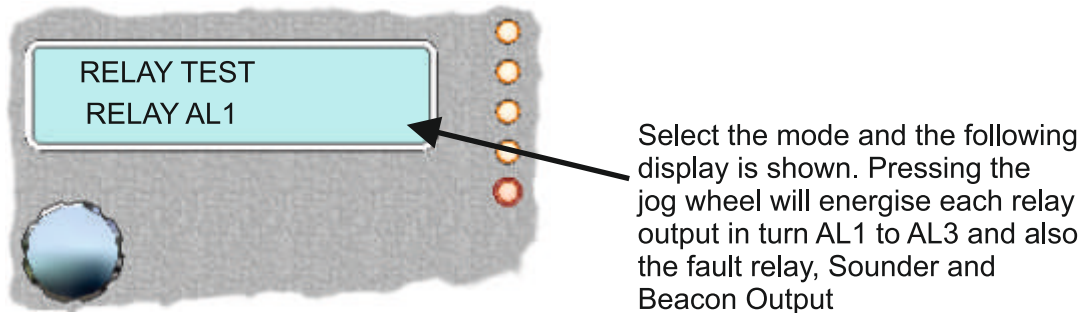

The TEST FIRE command

Factory configured versions of the Tocsin 700 are available with the capability to operate analogue thermal rate of rise and optical smoke detectors. This mode can be used when commissioning such detectors and provides a walk around test function.



In this mode of operation the following display is indicated with a 30 minute count down timer indicated on the bottom line of the display.

Whilst in this mode the panel will automatically reset any fire alarm input after 5 seconds. This allows a commissioning engineer to walk a site triggering detector heads to bump test them during test and commissioning of a system.

After the 30 minute period the panel returns to the ENGINEERS menu.

Press the jog wheel to exit this mode

The CHANGE CHANNEL command

This function can be used to move from one channel to another without exiting the ENGINEERS menu.

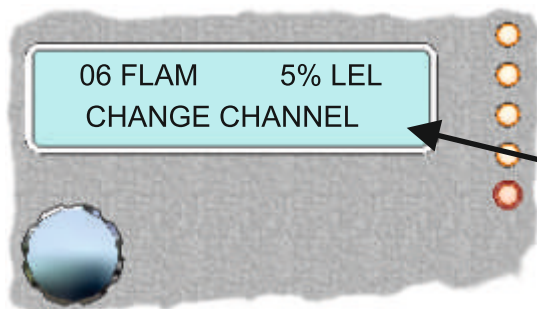

Select the mode and press the jog wheel to move sequentially between channels.



Menu Overview Production Menu

- 1
- LCD CONTRAST Set Display Brightness (1 to 10)
 - WARMUP MINS Set The Number of Minutes The panel is in Warm up Mode For (2 to 240)
 - T90 (Secs) Set the 4-20mA input Filter Level (0 to 100 Secs to T90)
 - FAULT THRESHOLD Set the Level for Fault Detection on the Addressable Comm's Ports (8 to 99 consecutive errors communicating to a sensor before reporting a system fault)
 - ALARM THRESHOLD Set the number of seconds the gas level must exceed the set alarm level for before setting the alarm relay.
 - MUTE MESSAGE Display 'PRESS TO MUTE ALARM' message on bottom line of display when an alarm is active (ENABLE or DISABLE option). If disabled then channel tag is displayed.
 - MUTE TIME Set the time period for which an alarm will stay muted before returning to its alarm condition
 - MODBUS ADDRESS Set the Modbus address default is 100
 - MODBUS BAUD RATE Set the Modbus baud rate default is 19200
 - MODBUS DATA BITS Set the Modbus data bits default is 8 bits
 - MODBUS PARITY Set the Modbus parity default is none
 - MODBUS STOP BITS Set the Modbus stop bits default is 1
 - CUSTOM GAS1 Select to add a custom gas type to the selectable list of gases. Input and store any 4 digit reference and it is added to the list of gas types that can be selected (i.e FLAM, CO etc)
 - CUSTOM GAS2
 - CUSTOM GAS3
 - CUSTOM GAS4
 - CUSTOM UNITS1 Select to add a custom UNIT to the selectable list of UNITS (for example PPM, %VOL etc. Input and store any 3 digit reference and it is added to the list of unit types that can be selected
 - CUSTOM UNITS2
 - RESET TO DEFAULTS Reset the control panel to its default values and settings.
 - REPROGRAM Select this option when updating the Tocsin 700 firmware using the Tocsin 700 PC Set up software. Note connect to the control panel first then enter factory settings mode and select REPROGRAM.
 - EXIT

WARNING
DO NOT ALTER THESE SETTINGS WITHOUT TRAINING OR
GUIDANCE FROM OLIVER IGD. IMPROPER SETTING OF
THESE PARAMETERS MAY RESULT IN UNINTENDED
OPERATION

11. Alarm Output Action

Rising and Falling Non Latching Alarms

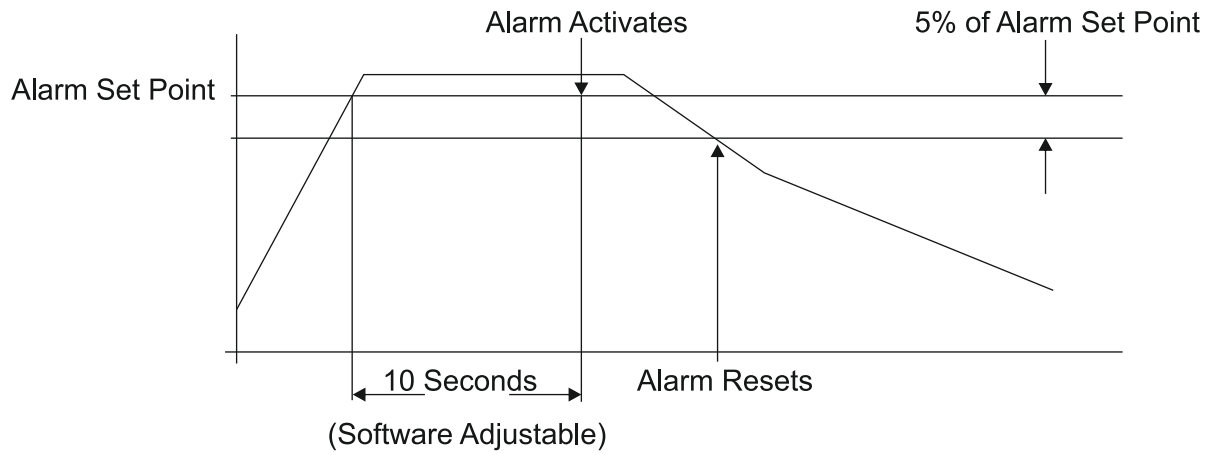

Rising and Falling Latching Alarms

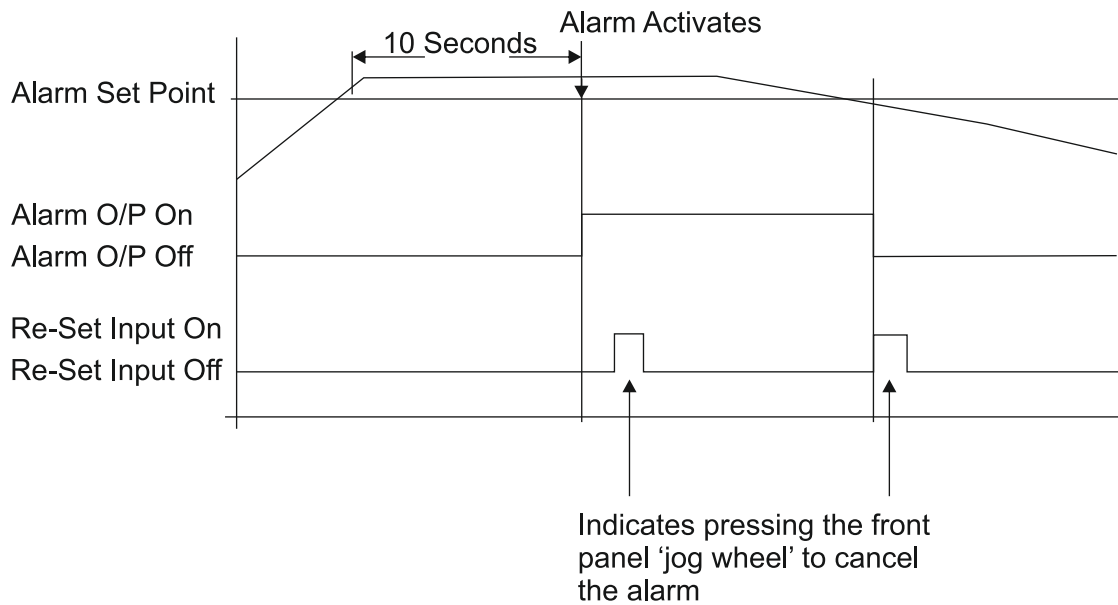

USING REMOTE 'MIMIC' PANELS

It is possible to connect two Tocsin 700 control panels to the same detectors. This allows you to have the flexibility to provide local and remote display and control. The following schematic and notes show the system requirement.

CABLING REQUIREMENTS.

Comms link between panels use min 1.5mm SQ screened 3 core cable for up to 1KM distance between panels. As indicated connect A,B and GND (0V) only.

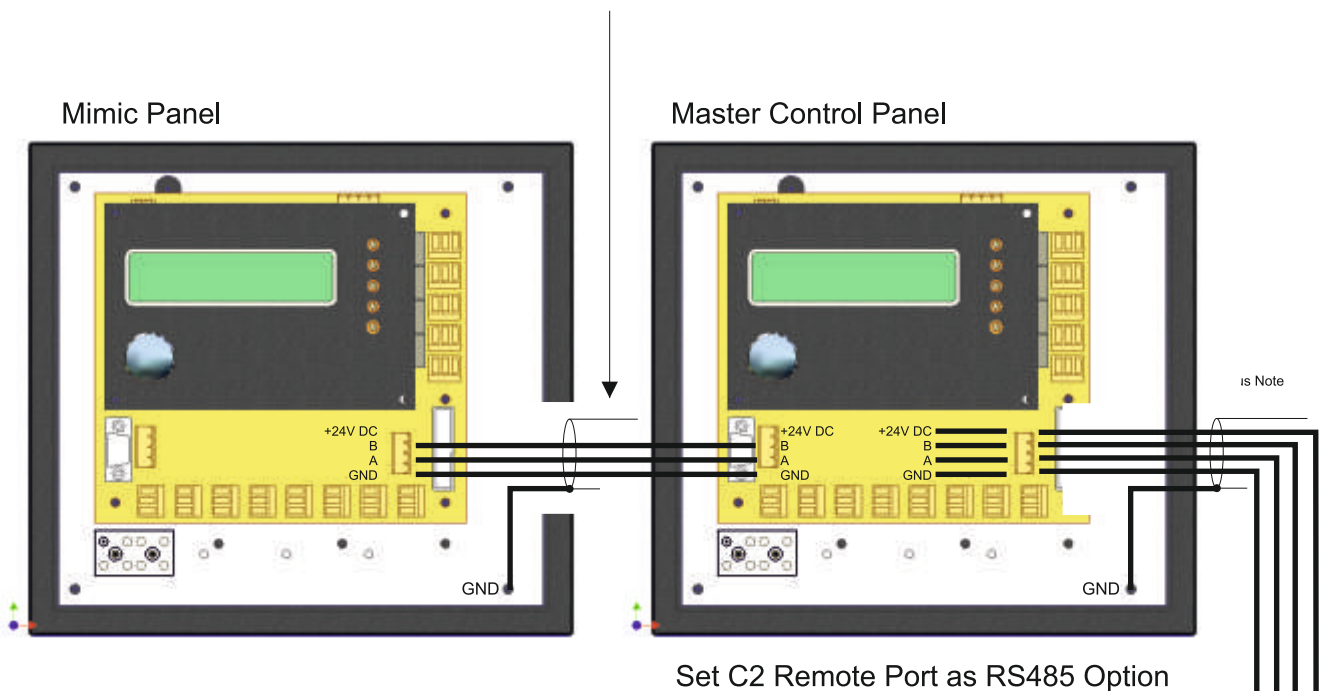

Note that the detectors in this example are communicating with both panels (the master panel is transparent to the mimic). Alarms are set on the control panel and so can be set up to be the same or different to meet the requirement.

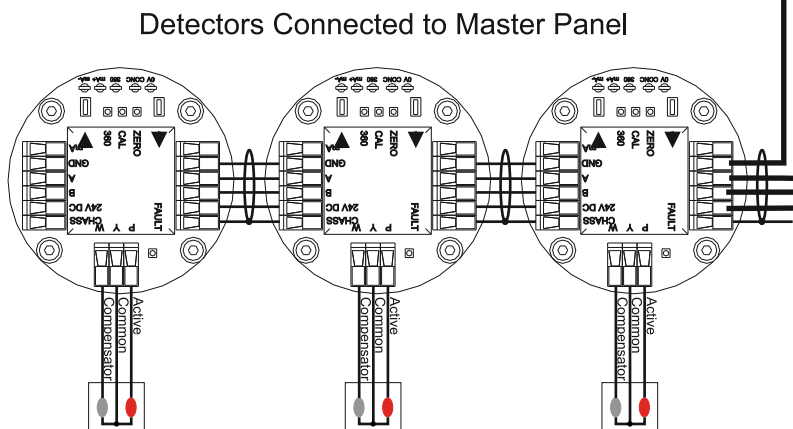

USING THE 485RPT MODULE TO SPLIT THE MAIN DATA HIGHWAY

In some circumstances more than one data highway may be required as well as a host Modbus connection. This can be achieved by fitting 485RPT modules to the main highway port. If this is to be implemented then one 485RPT module will be required per extra highway. The Tocsin 700 operates in the normal manner but it should be noted that there is still a limitation of 32 devices.

CABLING REQUIREMENTS.

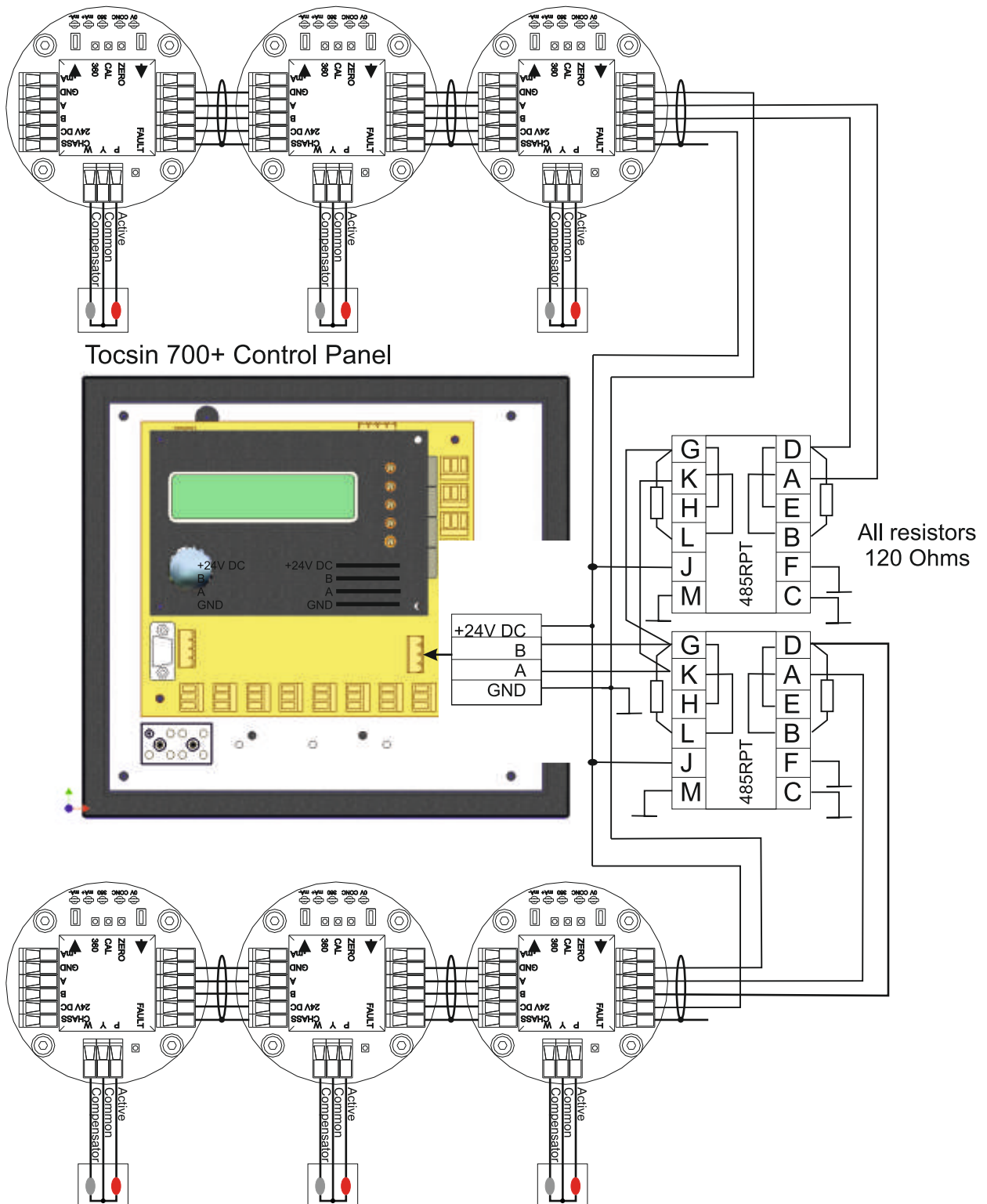

Integrated Battery Backup

The standard i700 is shipped with a 1.2AH Battery Backup Module

The battery is shipped separate from the control panel. Locate the battery in the panel once it is mounted as indicated in the overview diagram. The batteries are shipped ready charged for operation. Connect the battery to the charge management PCB with the cable provided

If required an additional 1.2AH battery pack can be fitted. This is supplied with a specific IGD cable set to add the battery in parallel to the existing battery. Third party units must not be used.

additional battery module part number I700-BAT-2

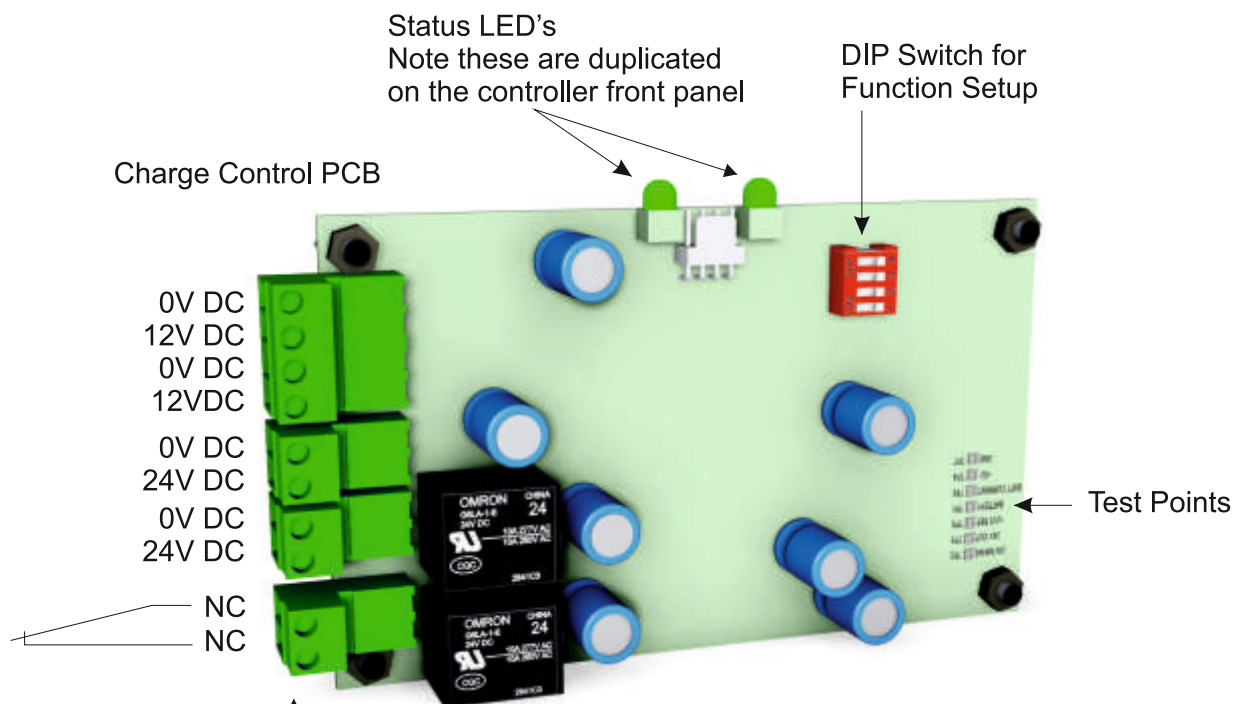

The Single Pole relay changes state when mains power is lost and the Tocsin 700 runs on the battery pack. It can therefore be used to remotely indicate mains power loss. The relay is rated at 7A 250V Non Inductive. Note the relay is powered in normal operation and opens on alarm or power loss.

Front Panel Status LED's

Mounted on the front panel of the battery backup module are two status LED's. The Following table indicates their operation.

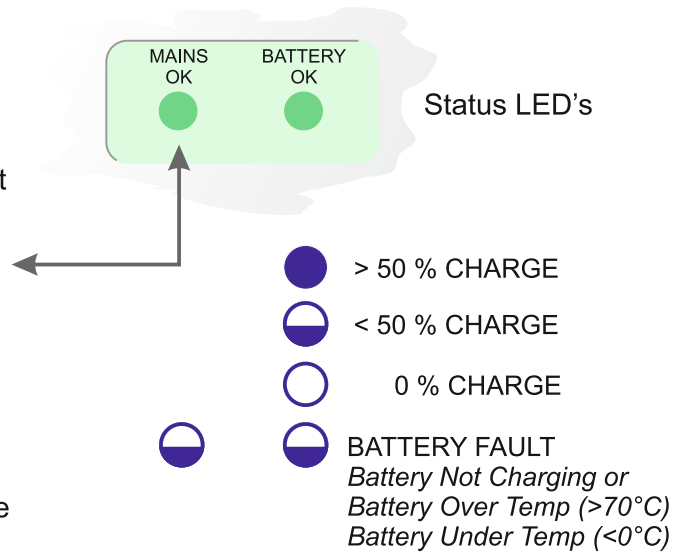

The Mains power LED will be on when the unit is operating from 110/230V AC. In this mode the battery backup module is inactive and being charged if required. The LED's will indicate the charge level as the battery is being re-charged.

If the Mains power LED is off, then the battery pack is active and providing backup power to the TOCSIN 700 controller and associated detectors. In this mode of operation the charge level indicator LED's indicate remaining battery power.

The battery pack will automatically switch into operation once the incoming 24V DC power rail drops below 22V.

Once battery power drops below 20V DC the controller determines that the battery pack is exhausted and power to the TOCSIN 700 controller will be turned off.

As soon as mains power is restored the controller will start re-charging the battery pack. The charge status will be indicated on the charge LED's. Typical re-charge time from flat will be approximately 5 hours.

Note that the status LED's take up to one minute to show correct status.

Both LED's will flash at start up as the controller makes an assessment of the battery and mains power status.

PCB DIP Switch Selection.

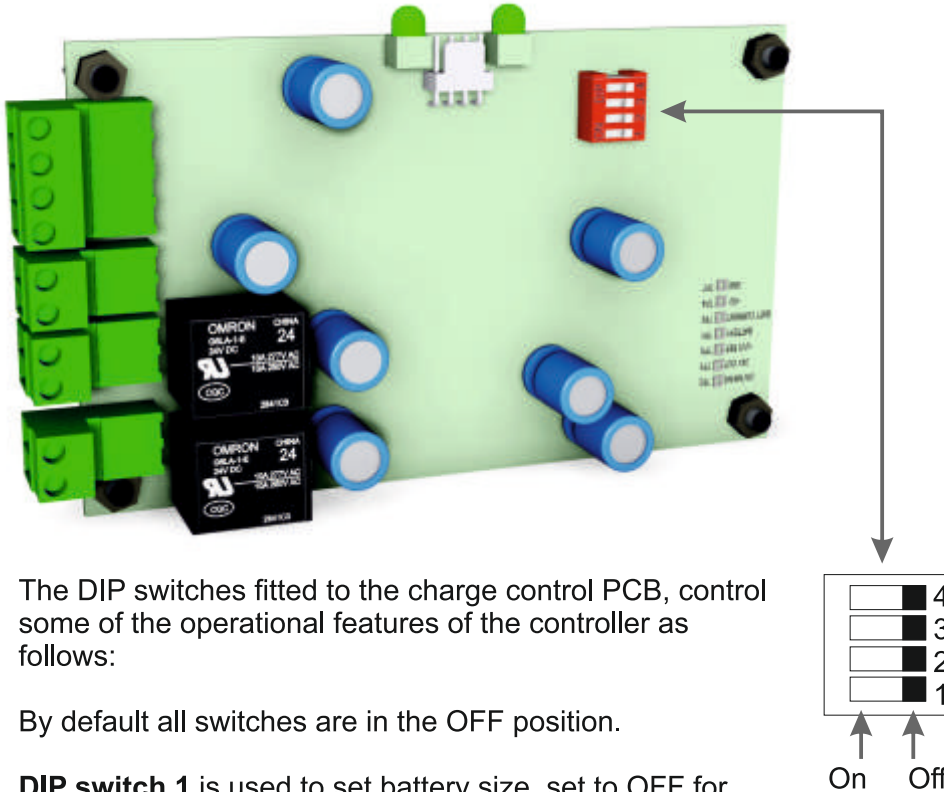

The DIP switches fitted to the charge control PCB, control some of the operational features of the controller as follows:

By default all switches are in the OFF position.

DIP switch 1 is used to set battery size, set to OFF for 1.2Ah batteries. Set to on for 7Ah batteries

DIP switch 2 sets the charge rate. set to OFF for max 300mA charge, this is the default max. Set to ON for 100mA charge, this setting is typically used in conjunction with the TOC-625 controller fitted with more than 4 detectors to limit the battery charge rate due to the smaller size of the TOC-625 PSU.

Note that the DIP switch setting is only read at power up. The system must be powered on and off (batteries disconnected) before the new setting takes effect.

For a new installation.

1. Connect the batteries allow system to power up on battery power
2. Switch on the mains power to the control panel

During this process observe the LED status and see the battery charge status then the switch over from battery power only to mains and battery charge.



Assessing A typical System For Battery Life

Use a table similar to the one indicated below to make an assessment of the system power requirement.

System Component	Alarm Mode Current	Quantity	Totals
Tocsin 700	0.25Amps	1	0.25Amps
Tocsin 920	0.5Amps	NA	NA
Tocsin 102 IR HC Detector	0.05Amps	4	0.2Amps
Tocsin 102 Pellistor HC Detector	0.13Amps	0	0
Tocsin 102 Toxic Gas Detector	0.02Amps	5	0.1Amps
Audible Alarm (Typical Example)**	0.12A	0	0
Visual Alarm (Typical Example)**	0.15A	1	0.15Amps
Additional Relay Units (8 Per Card)*	0.01A/Relay	0	0
Total System Current			0.7 Amps

The batteries used are 1.2AH units so using the previously indicated de-rating factors the expected battery life will be as follows:-

$$\text{Expected Operating Battery Life} = \frac{\text{Battery Capacity} \times \text{de-Rating Factor}}{\text{Total System Current}}$$

$$= \frac{1.2\text{AH} \times 0.75}{0.7\text{A}} = 1.3 \text{ Hours}$$

Note that in this example whilst the de-rating factor indicated was just 10% of battery capacity the next de-rating factor up was chosen.

Values indicated in the system component table are those for alarm condition to take account of the greatest possible current draw.



Assessing Battery Life

Battery back up life is dependant on the power consumption of the main control panel and the consumption of the detectors connected to it. The following table indicates how to assess the likely back up period for a system. Other factors can have an influence particularly how many charge/discharge cycles the batteries have been subjected to and the age of the batteries. It is recommended that batteries are replaced every two years as a matter of course.

System Component Power Consumption.

System Component	Monitor Mode	Alarm Mode
Tocsin 700	0.21Amps	0.25Amps
Tocsin 920	0.38Amps	0.5Amps
Tocsin 102 IR HC Detector	0.05Amps	NA
Tocsin 102 Pellistor HC Detector	0.13Amps	NA
Tocsin 102 Toxic Gas Detector	0.02Amps	NA
Audible Alarm (Typical Example)**	NA	0.12A
Visual Alarm (Typical Example)**	NA	0.15A
Additional Relay Units (8/16 Per Card)*	NA	0.01A/Relay

* Additional Relay Outputs Available In Blocks Of 8 For The Tocsin 700 System And Tocsin 920 System. Note when Making Power Assessments Only consider Active Relay outputs.

** Examples Only Check Supplied Data Sheets for chosen Products.

Battery De-Rating Factors

It is normal practice to de-rate battery performance with increasing current draw. The following table indicates the de-rating factors recommended to be applied in calculating the time any given system will run on battery battery power.

Power Level Drawn	De-Rating Factor
<10%	0.87
>10%<30%	0.75
>30%	0.58



MODBUS INTERNAL MEMORY MAP ADDRESSES

FUNCTIONS:

Command	Function	Register	Sensor	Returned Word
Read Sensor Conc	04	30,001 to 30,999	1 to 999	Min = 0 (-10% LEL) Max = 1200 (110% LEL) Resolution = 0.1%
Read Sensor Volts	04	31,001 to 31,999	1 to 999	Min = 0 (0.00V) Max = 500 (5.00V) Resolution = 0.01V
Read Area Status (T700 = Common Alarms)	04	32,001 to 32,999	AREA 1 to 999	Bit0 = AL1 Bit1 = AL2 Bit2 = AL3 Bit3 = Fault Bit4 = Sensor Disabled Bit5 – Bit15 = Spare
Read Sensor Status	04	33,001 to 33,999	1 to 999	Bit0 = AL1 Bit1 = AL2 Bit2 = AL3 Bit3 = Fault Bit4 = Sensor Disabled Bit5 = Sensor Fault Bit6 = Under Range Fault Bit7 = Over Range Fault Bit8 = Comms Fault Bit9 = Spare Bit10 = Spare Bit11 = Spare Bit12 = Spare Bit13 = AL1 Muted Bit14 = AL2 Muted Bit15 = AL2 Muted
Mute all Alarms	05	1	ALL	Pass = 0 Fail = 1
Reset all Alarms	05	2	ALL	Pass = 0 Fail = 1
Disable Sensor	05	1,001 to 1,999	1 to 999	Pass = 0 Fail = 1
Enable Sensor	05	2,001 to 2,999	1 to 999	Pass = 0 Fail = 1
Zero Sensor	05	3,001 to 3,999	1 to 999	Pass = 0 Fail = 1
Set Add. Relay = On	05	4,201 to 4,232	4201 to 4232	Pass = 0 Fail = 1,2,3 (1=Timeout, 2=Already Used, 3=Not Implemented)
Set Add, Relay = Off	05	5,201 to 5,232	4201 to 4232	Pass = 0 Fail = 1,2,3 (1=Timeout, 2=Already Used, 3=Not Implemented)

MODBUS INTERNAL MEMORY MAP ADDRESSES

COMMAND STRUCTURE

Parameter	Setting
1: Modbus Mode	RTU Mode Only
2: Operating Mode	Slave Mode Only
3: Response Time ^{#1}	Maximum = 100mS (5s for Zero Command)
4: Requests	Maximum = 32 per Second
5: Panel Address	100 to 131 (100=default)
6: Baud Rate	4800, 9600, 19200 (19200=default)
7: Start Bits	1
8: Data bits	8
9: Parity	None, Odd, Even (Odd=default. None=T700 only)
10: Stop	1, 2 (1=default & T700 only)
11: Flow Control	None
12: Physical Interface	2 Wire RS232, 2 Wire RS485 (2 Wire RS485=Optional on T900)
13: Bit Order	Least significant bit transmitted first
14: Byte Order	Least significant byte transmitted first
15: Inter-byte spacing	Maximum = 1.5 bytes times (781uS @ 19200 Baud)
16: Inter-packet spacing	Minimum = 3.5 bytes times (1823uS @ 19200 Baud)

Interfacing to the Remote Modbus Port

